

High-speed generation of neutronics-ready CAD models for DEMO design

M. Coleman^{a,b,*}, J. Shimwell^a, A. Davis^a, S. McIntosh^{a,c}

^a United Kingdom Atomic Energy Authority, Culham Science Centre, Abingdon, Oxfordshire OX14 3DB, United Kingdom

^b Department of Engineering, University of Cambridge, Trumpington Street, Cambridge CB2 1PZ, United Kingdom

^c ITER Organization, Route de Vinon-sur-Verdon – CS 90 046, 13067 St Paul Lez Durance Cedex, France

ARTICLE INFO

Keywords:

DEMO
CAD
Neutronics
Fusion

ABSTRACT

The creation of 3-D CAD models is one of the key steps in the fusion reactor design cycle, and is very much a recurring process. A common division of labour sees engineers, draughtspeople, and analysts iterate ideas, requirements and constraints, 3-D CAD model(s), and analyses, respectively, to iteratively converge upon a working design. Whilst this traditional approach may work well during detailed design (e.g. for ITER), we contend that it is sub-optimal during the *conceptual* design, due to the large overheads associated with dealing with relatively mercurial geometries, load cases, and boundary conditions.

In this work, we demonstrate that the automatic generation of 3-D CAD models for conceptual DEMO-class tokamak reactors is possible. The models, which comprise all major components ranging from the in-vessel components to the concrete radiation shield, are automatically produced for a given design point in approximately 30 s. This represents a significant acceleration of the traditional manual 3-D CAD model generation process for a typical reactor concept (~1 month). The CAD data are generated within a reactor design framework and can be used for a range of purposes. We highlight the use case for neutronics, by demonstrating that a simplified 3-D 360° global neutronics model can be automatically built from the ground up and run, using faceted geometry and smeared material properties, all in under 1 h.

1. Introduction

The design and analysis of future fusion reactors inevitably revolves around geometry. Whereas in the past machines were designed using only pencil and paper, one now invariably uses 3-D computer aided design (CAD) models.

Since the 1960s CAD has been at the forefront of engineering. Originally and literally quite a broad term, “CAD” has narrowed in definition, and is nowadays usually used to refer to three-dimensional (3-D) geometric models. Such 3-D CAD models are the currency of modern engineering, enabling a wide variety of different design and analysis activities to take place.

Surveying the use of 3-D CAD in the design of future fusion reactors today, we make the following observations:

- (i) Highly specialised proprietary software packages are used to create 3-D CAD models (typically CATIA®), which invariably have expensive licences for commercial use.
- (ii) The CAD software is used almost exclusively by dedicated users, often referred to as “designers” or “CAD technicians”, who have

usually received training in the software and spend the vast majority of their working time using it.

- (iii) Despite CAD software typically having very sophisticated methods for parametric design, these are seldom used. The norm in the community is manual CAD generation and modification.
- (iv) The CAD models are required as inputs to a broad range of analysis activities such as finite element analyses (FEA) and neutronics studies, yet they are not immediately compatible with either. CAD models are frequently “de-constructed” or “de-featured” to enable them to be used in subsequent analyses.

The above points lead to relatively lengthy design cycles: a CAD technician may spend a month building a 3-D CAD model before handing it over to a neutronicist, who may spend another month converting the geometry to a use-able format, before carrying out the analysis. This division of labour may make sense in the detailed engineering design phase (such as for ITER’s present needs), when design changes are relatively small, manufacturing costs dominate, and high-fidelity analyses are necessary. In the conceptual design phase, however, we believe

* Corresponding author at: United Kingdom Atomic Energy Authority, Culham Science Centre, Abingdon, Oxfordshire OX14 3DB, United Kingdom.

E-mail address: matti.coleman@ukaea.uk (M. Coleman).

that it introduces unnecessary and expensive overheads which hinder the design process.

The interface between CAD models and analysis models is, in some more sophisticated FEA software (e.g. ANSYS®), now handled quite well, as in-situ CAD creation packages are provided. For neutronics, however, no such software exists for complex geometric models. Several authors have tackled this problem (see e.g. [1,2]). Here we demonstrate that the creation of 3-D CAD models need not be as lengthy and expensive an exercise as is commonly thought. We generate a fairly complete 3-D CAD model automatically from the parameterised 2-D geometry procedures within the BLUEPRINT reactor design framework [3].

We further demonstrate the coupling of the 3-D CAD model to a simplified global neutronics model, which serves to calculate a range of integral values useful in the design of future fusion reactors.

2. Creation of reactor CAD model

This section describes the process of generation a CAD model for a tokamak parametrically. Many of the operations are straight-forward to grasp once the fundamentals are laid out, therefore we describe only certain steps in detail.

2.1. CAD function library

CAD software packages are built around a number of fundamental low-level data-types and functions which are not of interest to the average user. The higher-level functions, however, are typically exposed to the user in a clear and understandable form, and are fairly intuitive to most mechanical engineers – as they stem from machining and manufacturing steps.

Here we make use of an open-source CAD software package, Open CASCADE Technology (OCCT) [4], and more specifically a Python wrapper for it, Open CASCADE Community Edition (OCE) [5]. Around this CAD package, we have built an extremely simple set of tools, which allows geometry to be built parametrically directly within the BLUEPRINT framework. The use of open-source tools within BLUEPRINT is driven by the desire to carry out parameter scans using distributed computation, without resorting to purchasing multiple licences for commercial software. Note that excellent open-source options with much higher functionality also exist (such as FreeCAD [6], also built upon OCCT); however, for our purposes these are not required.

Two useful primitive shapes are supported: polygons and Bézier splines. The former are useful for simpler shapes, with few edges (such as squares), and the latter are useful and computationally convenient for curvier and more complex shapes (such as a figure of eight). Shapes combining both polygons and splines are also supported.

A range of simple high-level functions has been built around the manipulation of sets of 2-D coordinates: (i) extrude, (ii) revolve, (iii) sweep, (iv) loft, (v) Boolean fuse, and (vi) Boolean cut, based on the lower-level functions provided in OCE.

Some high-level geometry manipulations also come in useful: (i) rotate, (ii) translate, (iii) mirror, and (iv) scale.

These shape primitives, functions and manipulations are sufficient to create most simple engineering geometries, and when properly combined can produce some realistic geometries of fusion reactor components.

CAD boundary representation (BRep) objects created with the OCCT/OCE packages in the BLUEPRINT framework can be exported in two common and useful file formats: STEP and STL.

2.2. Component creation

The components themselves are created based on 2-D cross-sections generated inside the BLUEPRINT framework, see Fig. 1 (left). Groups of 2-D coordinates are then used to create 3-D CAD objects via a set of of

the aforementioned functions and manipulations. Fig. 2 depicts the procedure for a typical reactor vacuum vessel.

As these components are intended for use in a high-level global CAD model, the level of detail is only of the first order; we are interested here in “space reservations” of the various parts of the tokamak. Most components, such as the vacuum vessel, radiation shield, and divertor, are modelled using single space reservations and smeared material properties. For the breeding blanket, which naturally is of particular importance for the TBR result in particular, we make radial sub-divisions representing the first wall and armour, breeding zone, manifolds, and back supporting structure. Each of these radial layers has a different material composition, assuming a helium-cooled pebble bed (HCPB) design and thicknesses and material compositions from [7]. Similarly, we sub-divide the toroidal field coils into winding pack (with smeared properties assuming a Nb₃Sn conductor) and casing volumes (with a mixture of steel and helium).

2.3. Full reactor model

An assembly of the various components representing the full reactor can be created, see Fig. 1 (centre). Note that when one controls the geometry creation process from the ground up, one is also responsible to ensure that there are no clashes between components. This is fairly straightforward to control in the 2-D reactor cross-section, but care must also be taken that no clashes are introduced when porting the 2-D geometries into 3-D CAD models.

Component patterning is implemented to increase computational efficiency, but axisymmetry need not be maintained; individual components can trivially be introduced in different sectors (e.g. for a neutral beam injector).

Once the 2-D geometry objects have been created in the BLUEPRINT reactor design procedure, it takes approximately 30 s on a single Intel i-7 processor to build the full 360° 3-D CAD models for the plasma, blankets, divertors, vacuum vessel and ports, thermal shields, toroidal and poloidal field coils, central solenoid, cryostat vacuum vessel, and radiation shield. The run-time of this operation is dominated by Boolean operations on complex shapes, and could be reduced by parallelising the multiple independent processes, simplifying the shapes on which Boolean operations are performed, and improving the build procedures and their sequencing.

3. Coupling to neutronics model

In this section we describe our process for coupling the 3-D reactor CAD model generated in BLUEPRINT to a simplified global neutronics model, implemented in OpenMC [8]. This global model serves as a fairly low fidelity analysis to check integral parameters, such as the tritium breeding ratio, and heat deposition in various components. Such parameters inform later analyses and design activities in subsequent steps in the reactor design procedures in BLUEPRINT.

3-D CAD models (BRep objects) for each set of components are exported as STEP (AP214) files, with a separate file being made for each sub-component with a different material composition (e.g. magnet case, and magnet winding pack). A meta-data file is also created, assigning materials to each geometry file.

3.1. CAD model post-processing

In our procedure, we use Trellis Pro^{TM1} to check and prepare the STEP files created from the BRep objects for use in the direct accelerated geometry Monte Carlo (DAGMC) toolkit [9,10]. A number of algorithms

¹ Note that Trellis is commercial software, and requires a licence. In future we plan to drop its use in the procedure described here, replacing the imprinting and merging algorithm with an open-source tool.

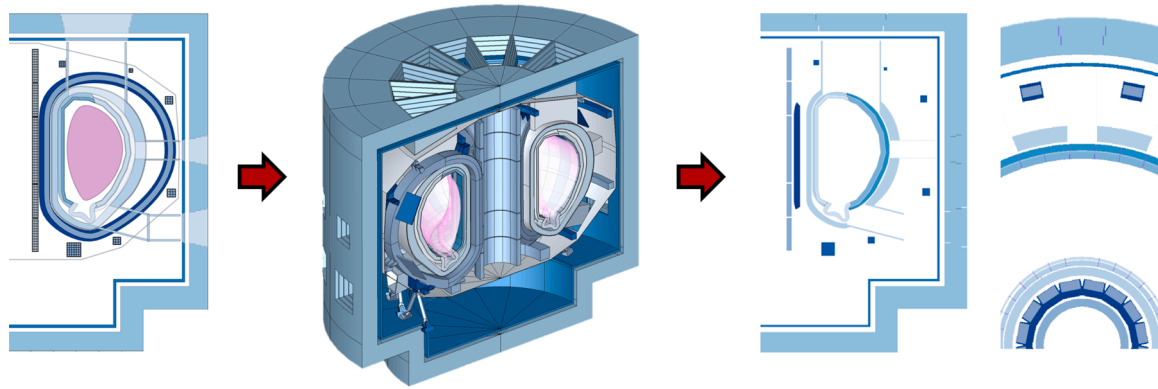

Fig. 1. The geometry creation procedure in BLUEPRINT, showing: (left) the 2-D reactor cross-section, (centre) the resulting 3-D CAD model, and (right) cropped views of the reactor cross-section and mid-plane plan in the radiation transport model.

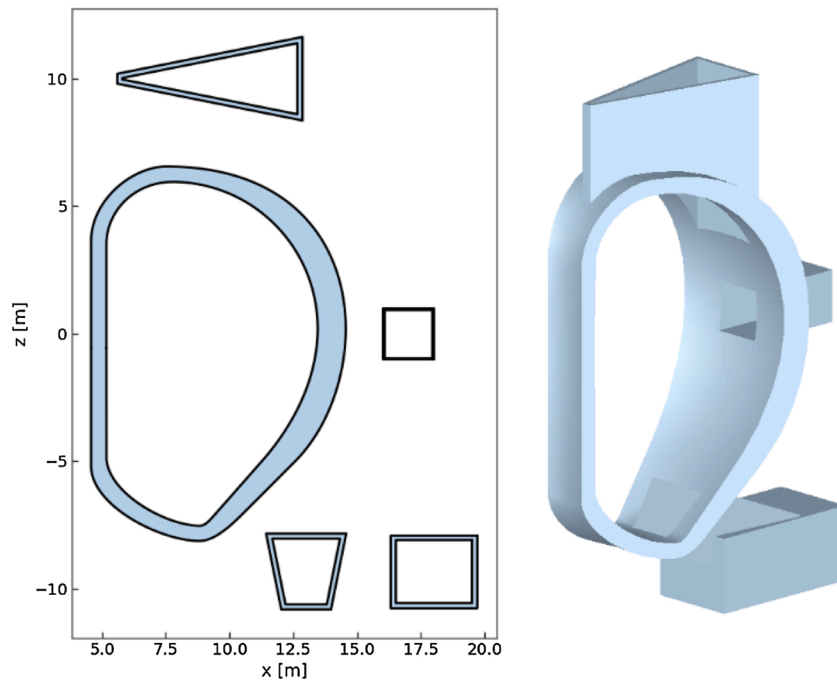

Fig. 2. (left) 2-D cross-sections of the vacuum vessel space reservation (right) the assembled CAD component. The main body is toroidally revolved about the machine axis, the port cross-sections are extruded into the main body, and Boolean cuts hollow out the penetrations into the main body.

are run:

- (i) **Imprinting:** creating common surface interfaces between coincident surfaces, potentially including additional common geometric curves.
- (ii) **Merging:** identifying identical surfaces across different volumes and creating a shared surface between them.
- (iii) **Making watertight:** ensuring that all volumes are fully closed, or “watertight”.
- (iv) **Removing duplicate surfaces, edges and vertices (if any).**
- (v) **Exporting the STEP files as faceted geometry with material information (h5m format).**

These steps can also assist with debugging, as they will point to problem areas in the CAD models, which can otherwise be hard to identify if issues arise within the radiation transport simulation. These checks do, however, come at a price in terms of run-time; with approximately twenty minutes being required to carry out these steps on this model (on a single core), with upwards of 500 volumes,

corresponding to approximately half a million facets. Volume clash checks can also be automated, and should take place prior to the steps listed above, but slow the procedure down considerably. Instead, great care is taken during the generation of the CAD objects in BLUEPRINT to ensure from the outset that no overlaps occur. This includes re-using the same curves for components that are in direct contact, and Boolean operations in select places to avoid geometry overlaps. As such the only overlaps that can occur are the result of numerical aberrations.

We also carefully select which CAD objects to use in the neutronics analysis. All key components are retained except for the thermal shield (which is a thin part with a complicated geometry), and the plasma (whose low density means it is effectively negligible in terms of neutron transport). Small, detailed features and parts (such as the coil gravity supports or poloidal field coil supports) are also deliberately left out of the analysis.

3.2. Material properties

Making use of the neutronics material maker package [11], material

properties are assigned to different geometry files. The material properties used for the various components (e.g. EUROfer, CuCrZr, tungsten, helium, etc.) are implemented as suggested in [12]. Volume-averaged (smeared) properties are used for each of the volumes, as in this global model our interest primarily lies in a rough estimation of integral properties, rather than detailed tallies. For more realistic results, heterogeneity is a prerequisite. This would however require more detailed geometry, which has not yet been included. The space reservations shown here could be parameterised in more detail for higher fidelity results. An example of how this might look for the breeding blanket can be found in Ref. [2].

3.3. Neutronics analysis

Our choice of OpenMC for radiation transport is motivated by the fact that it is open source, and its capability to handle faceted geometry (through the DAGMC toolkit, integrated in OpenMC), doing away with an otherwise fairly complex geometry pre-processing step common in other Monte Carlo neutron transport codes, namely the conversion of 3-D CAD models into constructive solid geometry (CSG) format.

We choose to use a full 360° model, as opposed to a reactor sector slice with a cyclical boundary condition, see Fig. 1 (right). This is to enable estimations of key reactor performance parameters with acyclical port penetrations (such as neutral beams, limiters, etc.). This is particularly important when estimating the TBR of a reactor; at present, for the EU-DEMO, a significant TBR penalty of 0.05 is assigned to penetrations, when compared with the TBR evaluated over a cyclical geometry with no penetrations [13].

Neutron interaction data from FENDL 3.1d [14], and TENDL-2017 [15] were used for the simulation. TENDL-2017 data was used when FENDL 3.1d data was not available for the isotope. For photon interaction, data from ENDF 7.1 [16] was used. These libraries were automatically downloaded and processed using nuclear data processing scripts that have been added to the OpenMC data repository [17].

An axisymmetric, volumetric D-T fusion neutron source term, based on [18], parameterised in OpenMC [8] is used. The source term procedure is provided with the various reactor design parameters from the overall framework (plasma geometry, temperatures, and fusion power). D-D fusion is ignored.

Coupled neutron and photon transport was used in order to estimate the total heat deposition and energy multiplication in the reactor.

3.4. Results and discussion

For integral neutronics parameters in the regions near the plasma, converged results can be obtained with relatively few neutrons. Here, we run 100,000 neutrons on 64 cores, taking approximately 25 min in real time. One third of this duration is taken up by non-scalable activities such as the loading of data, initialisation of the model, etc. The remaining two thirds of this time is for the actual radiation transport calculation, and could be accelerated by using more cores.

The tritium breeding ratio (TBR) of this machine was found to be 1.07, with no penetrations into the blanket accounted for. Fig. 3 shows the CAD used in the neutronics model, and the regions of tritium production in the blanket segments. The total heat deposition (neutronic and photonic) in the blanket was found to be 1930 MW, and in the divertors this value was 125 MW.

Given that we are using a HCPB blanket material composition and radial decomposition from 2015 [7], but with a thinner outboard blanket segment (1.1 m instead of 1.3 m), it is perhaps not surprising that we find lower TBR values (1.07 here, compared to 1.20 in [7]). Given that the target TBR for such axisymmetric reactor models² is

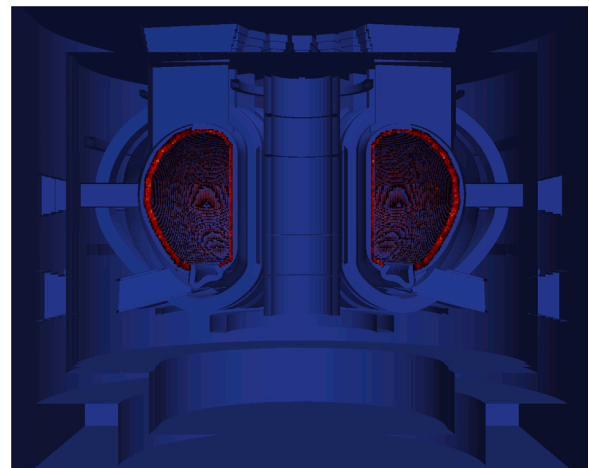

Fig. 3. The OpenMC neutronics model, showing the regions of tritium production in red. (For interpretation of the references to color in this figure legend, the reader is referred to the web version of this article).

normally taken to be around 1.10, this reactor and blanket would need to be re-designed somewhat to meet this criterion. This could involve thickening the blanket, or making more efficient use of the allocated space; increasing the size of the breeder zone or altering its material composition for improved breeding.

The results from the global neutronics model are used as inputs in further analyses in the rest of the BLUEPRINT framework, such as in the reactor power balance calculation, where the heat deposition in the various components can be ultimately used to estimate the overall efficiency of the reactor. These integral neutronics parameters are thus important performance parameters for the reactor. The point of having a relatively low fidelity model is to enable different designs to be explored from a neutronics perspective relatively rapidly. This in turn paves the way for design optimisation of the reactor geometry with preliminary TBR and neutronic heating estimates.

For regions further away from the plasma, considerably more neutron histories would need to be simulated in order to obtain converged results, preferably along with some advanced variance reduction techniques, which are not yet available in OpenMC.

The classical design iteration involving reactor engineers, CAD technicians, and neutronicists in order to carry out neutronics simulations on conceptual designs takes orders of magnitude longer than the process presented here. Here the user is at once reactor designer, CAD technician and neutronicist, significantly reducing the time and cost of carrying out preliminary neutronics analyses.

The next major step in this work is to increase the heterogeneity of the model, particularly for the blankets and other in-vessel components, to increase the fidelity of the simulation. In the interest of keeping run-times low, a level of detail (geometry and heterogeneity) could be settled upon, providing the user with sufficiently accurate integral parameter results (compared with models with higher levels of detail), for the fastest possible run-time.

4. Conclusions

We have demonstrated that the creation of 3-D CAD models for conceptual fusion reactor design need not take as long as it presently does, and that crude neutronics results can be obtained much faster than is the norm today. Using a reactor design framework and the methodologies described here, one can go from a 1-D systems code solution right up to integral results from a simplified radiation transport simulation in a full 3-D 360° model in slightly over 45 min on a single 64-core computer. This is thanks firstly to the use of automated, parameterised CAD model creation, and secondly to the use of faceted geometry in

² That is to say, not accounting for any penetrations through the breeding blankets or non-breeding zones other than the divertors.

Monte Carlo neutron transport codes.

The radiation transport model we have presented here is not intended to be high-fidelity; the aim is rather to inform reactor design through rapid Monte Carlo radiation transport simulations. Design permutations or parameter explorations thus become possible, and regions of the design space can be converged upon prior to carrying out more detailed design and analysis studies.

Conflict of interest

None declared.

Authors' contribution

Matti Coleman: Conceptualization, Methodology, Software, Formal analysis, Investigation, Writing, Visualization. **Simon McIntosh:** Conceptualization, Methodology, Software. **Jonathan Shimwell:** Conceptualization, Methodology, Software, Formal analysis, Investigation, Visualization. **Andrew Davis:** Methodology, Software, Supervision.

Declaration of Competing Interest

The authors report no declarations of interest.

Acknowledgements

We would like to thank Dr G. T. Parks (University of Cambridge) and Dr E. Surrey (UKAEA) for their mentorship, support, wise words and guidance.

This work has been funded by the RCUK Energy Programme [grant number EP/1501045]. To obtain further information on the data and models underlying this paper please contact PublicationsManager@ccfe.ac.uk.

References

- [1] A. Davis, J. Barzilla, A. Ferrari, K.T. Lee, V. Vlachoudis, P.P.H. Wilson, FluDAG: a CAD based tool for high energy physics, *Nucl. Instrum. Methods Phys. Res. Sect. A* 915 (2019) 65–74.
- [2] J. Shimwell, R. Delaporte-Mathurin, J.-C. Jaboulay, J. Aubert, C. Richardson, C. Bowman, A. Davis, A. Lahiff, J. Bernardi, S. Yasin, X. Tang, Multiphysics analysis with CAD-based parametric breeding blanket creation for rapid design iteration, *Nucl. Fusion* 59 (2019) 046019.
- [3] M. Coleman, S. McIntosh, BLUEPRINT: a novel approach to fusion reactor design, *Fusion Eng. Des.* 139 (2019) 26–38.
- [4] Open CASCADE, 2015. <https://www.opencascade.com/content/previous-releases>.
- [5] T. Paviot, Open CASCADE Community Edition, 2017. <https://github.com/tpaviot/oce>.
- [6] "FreeCAD." <http://www.freecadweb.org>.
- [7] F. Hernández, Q. Kang, B. Kiss, P. Norajitra, G. Nádas, P. Pereslavtsev, C. Zeile, HCPB Design Report 2015, Tech. Rep. EFDA_D_2MNBH9, Karlsruhe Institute for Technology, 2016.
- [8] P.K. Romano, N.E. Horelik, B.R. Herman, A.G. Nelson, B. Forget, K. Smith, OpenMC: a state-of-the-art Monte Carlo code for research and development, *Ann. Nucl. Energy* 82 (2015) 90–97.
- [9] T.J. Tautges, P.P.H. Wilson, J.A. Kraftcheck, B.M. Smith, D.L. Henderson, Acceleration Techniques for Direct Use of CAD-Based Geometries in Monte Carlo Radiation Transport, American Nuclear Society – ANS, United States, 2009.
- [10] U. of Wisconsin Computational Nuclear Engineering Research Group, Direct Accelerated Monte Carlo Geometry Toolkit, 2019.
- [11] J. Shimwell, M. Coleman, Neutronics Material Maker: A Tool for Making Neutronics Material Cards for Use in Codes Such as Serpent, 2018 original-date: 2018-02-12T11:01:33Z.
- [12] U. Fischer, Guidelines for Neutronics Analyses, Tech. Rep. EFDA_D_2L8TR9, Karlsruhe Institute for Technology, 2016.
- [13] U. Fischer, C. Bachmann, I. Palermo, P. Pereslavtsev, R. Villari, Neutronics requirements for a DEMO fusion power plant, *Fusion Eng. Des.* (2015) 2134–2137.
- [14] International Atomic Energy Authority Nuclear Data Services, "FENDL-3.1d, 2018.
- [15] A.J. Koning, D. Rochman, J.C. Sublet, N. Dzysiuk, M. Fleming, S. van der Marck, TENDL: complete nuclear data library for innovative nuclear science and technology, *Nucl. Data Sheets* 155 (2019) 1–55.
- [16] P. Obložinský, Special issue on ENDF/B-VII.1 Library, *Nucl. Data Sheets* 112 (2011) ii.
- [17] OpenMC nuclear data processing scripts. <https://github.com/openmc-dev/data>.
- [18] C. Fausser, A.L. Puma, F. Gabriel, R. Villari, Tokamak D-T neutron source models for different plasma physics confinement modes, *Fusion Eng. Des.* 87 (2012) 787–792.