



Contents lists available at ScienceDirect

## Fusion Engineering and Design

journal homepage: [www.elsevier.com/locate/fusengdes](http://www.elsevier.com/locate/fusengdes)

## EU DEMO Remote Maintenance System development during the Pre-Concept Design Phase

Oliver Crofts<sup>a,\*</sup>, Antony Loving<sup>a</sup>, Marc Torrance<sup>a</sup>, Stuart Budden<sup>a</sup>, Ben Drumm<sup>a</sup>, Tristan Tremethick<sup>a</sup>, Didier Chauvin<sup>b</sup>, Mikko Siuko<sup>c</sup>, William Brace<sup>c</sup>, Viktor Milushev<sup>d</sup>, Martin Mittwollen<sup>d</sup>, Timo Lehmann<sup>d</sup>, Felix Rauscher<sup>d</sup>, Georg Fischer<sup>d</sup>, Paolo Pagani<sup>d</sup>, Yan Wang<sup>d</sup>, Carsten Baars<sup>d</sup>, Alberto Vale<sup>e</sup>

<sup>a</sup> RACE, UKAEA, Culham Science Centre, Abingdon, Oxon OX14 3DB, UK

<sup>b</sup> EUROfusion Consortium, PPP&T Department, Boltzmannstraße 2, 85748 Garching, Germany

<sup>c</sup> VTT Technical Research Centre of Finland, P.O. Box 1000, FI-02044 VTT, Finland

<sup>d</sup> KIT Institute of Materials Handling and Logistics, Gotthard-Franz-Straße 8, bldg.50.38, 76131 Karlsruhe, Germany

<sup>e</sup> IST, Instituto Superior Técnico, Av. Rovisco Pais 1, 1049-001 Lisboa, Portugal

### ARTICLE INFO

#### Keywords:

DEMO  
remote  
maintenance  
pre-concept  
blanket  
divertor  
handling  
port  
architecture

### ABSTRACT

During the EU DEMO Pre-Concept Design Phase, the remote maintenance team developed maintenance strategies and systems to meet the evolving plant maintenance requirements. These were constrained by the proposed tokamak architecture and the challenging environments but considered a range of port layouts and handling system designs. The design-driving requirements were to have short maintenance durations and to demonstrate power plant relevant technologies. Work concentrated on the in-vessel maintenance systems, where the design constraints are the most challenging and the potential impact on the plant design is highest. A robust blanket handling system design was not identified during the Pre-Concept Design Phase. Novel enabling technologies were identified and, where these were critical to the maintenance strategy and not being pursued elsewhere, proof-of-principle designs were developed and tested. Technology development focused on pipe joining systems such as laser bore cutting and welding, pipe alignment, and on the control systems for handling massive blankets. Maintenance studies were also conducted on the ex-vessel plant to identify the additional transport volumes required to support the plant layout. The strategic implications of using vessel casks, and of using containment cells with cell casks, was explored. This was motivated by the costs associated with the storage of casks, one of several ex-vessel systems that can drive the overall plant layout.

This paper introduces the remote maintenance system designs, describes the main developments and achievements, and presents conclusions, lessons learned and recommendations for future work.

### Introduction

The EU DEMO is a future Demonstration Fusion Power Plant whose architecture can be traced back through ITER and the Joint European Torus (JET) to the first port-based tokamaks.

DEMO ‘must demonstrate the necessary technologies [...] for safely generating electricity consistently, and for regular, rapid, and reliable maintenance of the plant. The design of such a plant must take account [...] of engineering and technological limitations’ [1].

To generate electricity efficiently, future commercial fusion power plants need to have high availability [2]. The requirement for rapid and

reliable maintenance is a challenging step-change from the needs of current research oriented fusion reactors. This paper reports activities in remote maintenance (RM) systems development during the DEMO Pre-Concept Design Phase (PCDP) from 2014 to 2020.

An efficient maintenance system requires a tokamak architecture that is compatible with simple, rapid maintenance. Consequently, RM systems are design-driving, directly influencing the DEMO plant design and layout.

In-vessel maintenance strategies for DEMO started by looking at all viable options for removing the blankets and divertor cassettes for a single-null DEMO baseline design. This machine architecture has a

\* Corresponding author

E-mail address: [oliver.crofts@ukaea.uk](mailto:oliver.crofts@ukaea.uk) (O. Crofts).

<https://doi.org/10.1016/j.fusengdes.2022.113121>

Received 10 December 2021; Received in revised form 11 March 2022; Accepted 28 March 2022

Available online 10 April 2022

0920-3796/Crown Copyright © 2022 Published by Elsevier B.V. This is an open access article under the CC BY-NC-ND license (<http://creativecommons.org/licenses/by-nc-nd/4.0/>).

single divertor at the bottom [3].

To achieve the strong requirement for efficient maintenance, the tokamak layout must be arranged to make maintenance simpler. This requires a balance to be struck between the cost and performance of the plant and its maintenance. The maintenance system design work that has been conducted in the PCDP has started to provide the maintenance cost and performance data that is required for the assessment of a range of maintenance strategies. The results are provided in the maintenance developments descriptions for each of the design areas (§3).

## Background – the maintenance challenge

### The magnetic cage

DEMO is a port-based tokamak fusion reactor where the fusion reaction takes place in a plasma at very high temperatures in a vacuum vessel. Magnets are used to confine the plasma [4], and these form a magnetic cage around the vessel (Fig. 1). There are 16 Toroidal Field Magnets. This means there are 16 sectors, each with 5 breeding blankets, 3 divertor cassettes and an upper, lower, and equatorial port, and hence there are 48 divertor cassettes and 80 breeding blankets in total.

Thick shielding is required around the outside of the machine due to high energy neutrons created in the fusion reaction. The high neutron flux damages the plasma facing components which requires them to be replaced several times during the life of the machine. These components are the breeding blankets on the vessel walls and the cassettes that form the divertor at the plasma null strike points.

The magnetic cage and thick shielding mean that long narrow ports are the only access routes into the vessel through which to inspect, repair and replace components.

Maintenance of the blankets and cassettes requires dexterous handling of massive payloads through sometimes complex paths and with small clearances. The blankets are 12m long and weigh up to 80 tonnes. By comparison, the ITER blankets weigh 4.5 tonnes and the ITER divertor cassettes 10.3 tonnes.

Dexterous handling of such payloads is a handling challenge that has never been tackled before. It is far simpler, and therefore faster and cheaper, to have a plant layout that allows a crane to perform the heavy lifting. But on DEMO, the unique constraint of the magnetic cage prevents this normal approach to handling, requiring components to be manoeuvred into position from behind the magnets before they can be

extracted through the ports.

### Port arrangement in DEMO

The DEMO port arrangement has a major impact on the maintenance. Several arrangements were considered in a study in 2013 and the option selected was the ‘Vertical maintenance’ arrangement in which the blankets are extracted upwards, through a vertical upper port (Fig. 2) and the divertor cassettes are extracted through an angled lower port.

The vertical maintenance approach was used as the reference concept throughout the PCDP because it presented the best compromise among the four alternatives (Fig. 2) in terms of complexity of remote maintenance solutions, accessibility of in-vessel components, kinematics of component replacement, implications on ex-vessel systems, structural integrity, and pipework access.

It does not offer the best access to in-vessel components, due to the limited port size, but provided a maintenance solution can be found, this drawback was outweighed by advantages both for the hardware kinematics at the lower port and avoiding the need for a pit below the vessel but also for improved plasma control and structural integrity achieved through having smaller ports, allowing better magnet positions and larger continuous toroidal conductive paths around the vessel.

Heating and diagnostic systems could make the removal of the in-vessel components more complicated by constraining the removal path or simply by adding component variants. The base assumption for Remote Maintenance is that these systems do not impact the maintenance by being part of the components or being retracted before maintenance however at the PCD stage, limited information was available about the maintenance impact of these systems or from the potential introduction of limiters to protect the in-vessel components and this is an important part of the ‘maintenance specification’ to be developed during the CDP.

### Access to all upper and lower ports for maintenance

One of the key strategies for the PCDP was to have access through all the upper and lower ports for maintenance of the blankets and divertor. This means that part of every blanket and every divertor cassette can be seen through a port (see Fig. 7) which provides two significant benefits to maintenance:

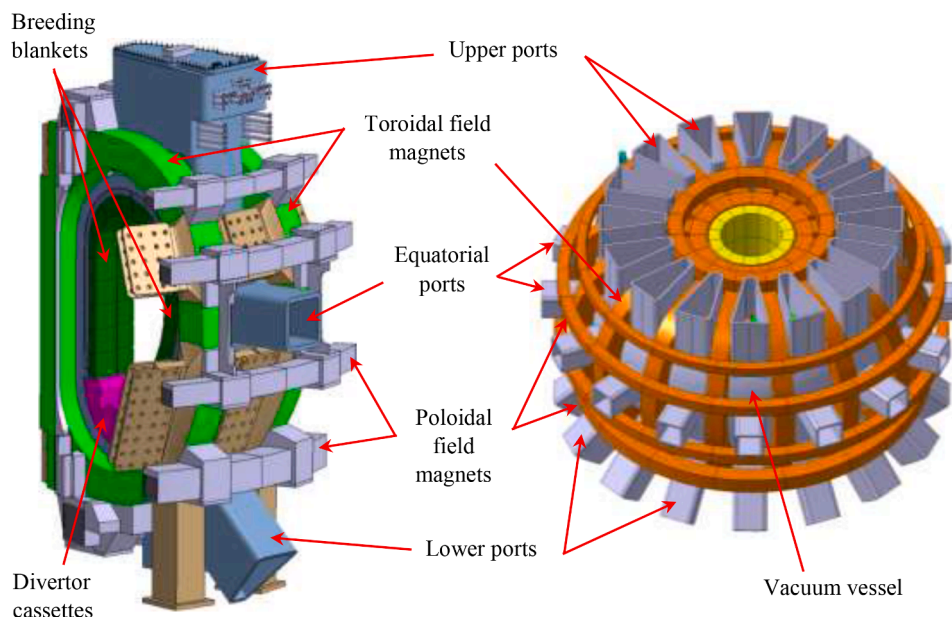

Fig. 1. Left: section view of one machine sector; right: the magnetic cage, vessel, and ports

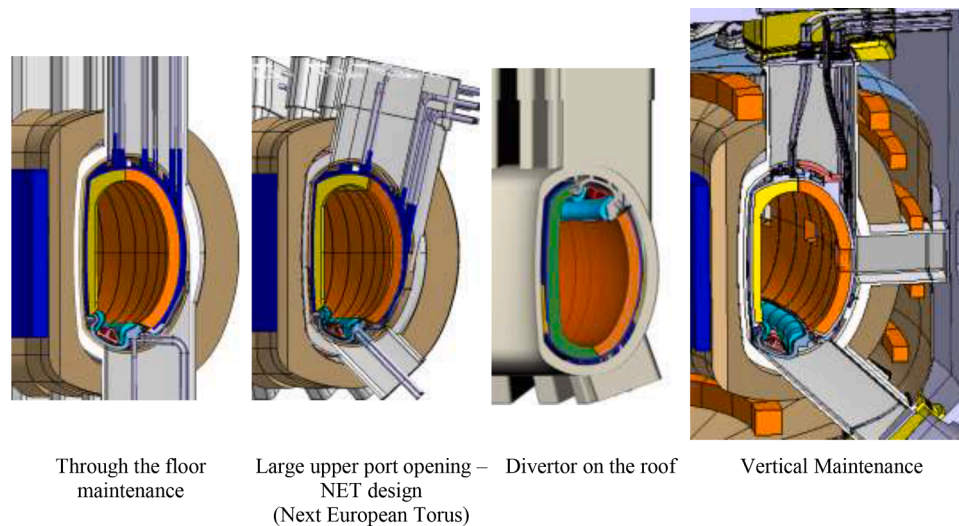

Fig. 2. DEMO port configurations considered for down-selection in 2013

- i maintenance can be carried out from within the port where radiation and contamination levels are lower, and viewing, sensing and rescue options are significantly better compared to the alternative which requires toroidal movers that must be installed and move toroidally within the vessel to collect the blanket segments or divertor cassettes and bring them to the port for extraction by the port-based system.
- ii service pipes can run directly through the ports and into the components, without the need for in-vessel toroidal pipe runs or additional vessel penetrations or the need to form welded joints with old pipework which needs surface preparation before welding to cut away the previous weld affected zone, and which will have some helium present in the material which can affect the weld quality.

#### The in-vessel environment

The gamma dose rate early in the maintenance phase can approach 2000 Sv/h near the centre of the machine (for comparison the maximum dose rate in ITER is expected to be about 500 Sv/h).

In the ports the dose rate is only limited to  $\sim 223\text{C1 Sv/h}$  by the presence of the blankets, which provide shielding (Fig. 3). When the outboard blankets are removed, or when an activated component is being moved through the port, the dose rate is significantly higher.

The neutron activation of the components releases heat during the maintenance phase. The components will be cooled whenever possible. During removal from the vessel the cooling must be disconnected, and their temperature is expected to exceed  $200^\circ\text{C}$ .

The strong magnetic field during operation generates a residual field in the components which can affect the maintenance systems and sensors. The residual magnetic field is 40 mT. Although small compared to the operating magnetic field, this is still 1000 times greater than earth's magnetic field.

The plasma erodes the tungsten armour on the front face of the plasma facing components, producing very fine contaminated dust. The fusion power plant uses and produces tritium, which is radioactive, highly mobile and can penetrate most materials, resulting in further contamination. This places a strong containment requirement on DEMO to prevent the spread of contamination [5] which in turn can have a strong influence on the maintenance process (see §3.3) and requires the in-vessel maintenance system hardware to be easily decontaminable.

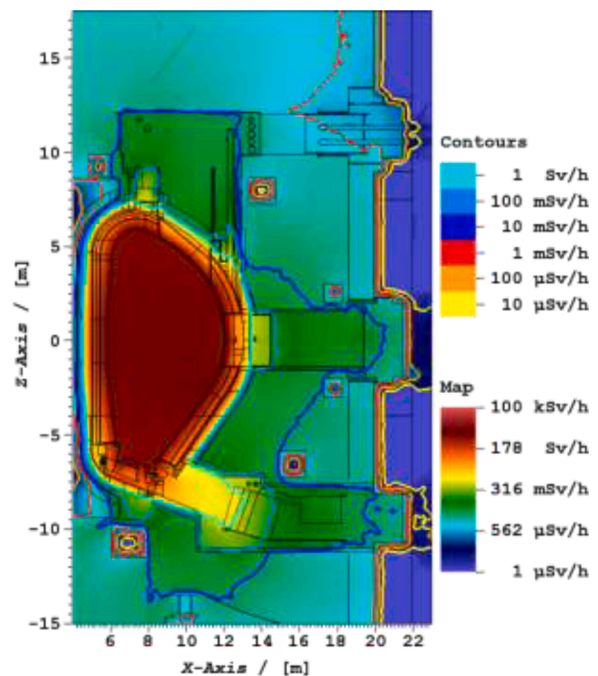

Fig. 3. Estimated dose rate in DEMO in a vertical plane through the port centre at the start of maintenance, approximately 1 month after deuterium-tritium plasma operations.

#### DEMO Remote Maintenance developments and achievements

##### Remote maintenance philosophy and strategy

During the PCDP, the DEMO Remote Maintenance Work Package (WPRM) developed a maintenance philosophy that distinguishes the maintenance strategy from the maintenance system.

- i The maintenance strategy is a transverse function that describes how maintenance will be carried out on the plant. It interfaces with the plant design and defines the maintenance processes.
- ii The maintenance system is the combination of people and equipment required to execute the maintenance processes and realize the maintenance strategy.

Throughout the PCDP, the remote maintenance strategy adapted to changes in the DEMO plant design. The original vertical maintenance concept shown in Fig. 2 developed in a direction that reduced access space and consequently increased the challenge for remote maintenance. Fig. 4 shows the limited space available between the bioshield and the cryostat, between the thermal shield and the vacuum vessel and critically between the vacuum vessel and the blankets.

#### *In-vessel remote maintenance systems*

Owing to complexity of in-vessel component (IVC) handling, IVC remote maintenance was a principal focus for WPRM during the PCDP. The principal IVCs are shown in Fig. 5.

Fig. 6 provides a more detailed view of the upper port area and illustrates why the most challenging in-vessel remote maintenance operations are those involving the breeding blankets. Disconnection and reconnection of the blanket service pipes, and extraction and insertion of the breeding blankets have dominated the WPRM programme. This is because these challenges bound other in-vessel remote maintenance operations in terms of hazard, mass, kinematics, etc.

#### *Breeding blanket handling system concepts*

The original blanket configuration for DEMO was selected to give the minimum number of blankets that can all be handled from the ports where the deployment is simpler, and the radiation levels are lower. This is five blankets per port sector that run the full height of the machine, three outboard and two inboard, see Fig. 7. The centre outboard blanket (yellow) can be removed directly and then the lateral outboard and finally the inboard blankets.

As a direct consequence of the size of the access port, four of the five blanket modules at each port have a centre of mass that is outside the port area. To reduce neutron streaming reaching the vessel, the DEMO plant design team set maximum gap between breeding blankets at 20 mm.

By changing the first central outboard blanket to have parallel faces, rather than radial, it became possible to have the first movement in the removal process in the radial direction to move it clear of the keys used to react toroidal loads into the vessel. The profile of the upper port was also refined, becoming wider above the poloidal field magnet, providing increased space for pipes and for manoeuvring components.

Despite these improvements, breeding blanket handling remained the bounding remote maintenance challenge. This was because of the combination of height (12 m), mass (~223C80 tonnes) and the target positional accuracy of  $\pm 5$  mm driven by the gap between blankets and a

small tolerance.

Fig. 8 shows the required motion of the first inboard blanket segment. The segment must be moved down to be clear of the second inboard blanket. The outline of the second blanket is shown by the red line. This requires the divertor to be removed before blanket maintenance.

Each of the blanket movements has an impact on the design of the removal mechanism in terms of the range of motion and loads applied. It should also be noted that following plasma operations, the effect of neutrons on the blankets and their attachments can cause swelling, changes in material properties, such as stiffness and it is estimated that individual blanket module geometry may have changed by as much as 100 mm. It is almost certain that during installation and removal, blankets will bump or rub against adjacent blankets. Snagging, galling, or seizing between adjacent blankets or against highly loaded location features could occur so the components must be designed to ensure this cannot occur.

The kinematics shown in Fig. 8 require movement in all three directions, x, y and z, and rotation about y. However, due to deflections, distortion and manufacturing and assembly tolerances, some rotation about x and z will also be required to ensure accurate positioning and translation of the blankets. A system capable of moving with six degrees-of-freedom is therefore required.

It was also recognized that the bending moments required to handle the blankets in excess of 1 MN.m would cause significant deflection of the mover so it would be beneficial if the mover could react the loads as close to the blanket as possible, which in practical terms is the top of the port. Most of the proposed mover concepts are therefore lowered and attached to the top of the port from where they can manoeuvre the blankets until the centre of gravity of the blanket is below the port, at which point the mover, with blanket attached, can be withdrawn vertically from the vessel using a rope lift.

There are many design drivers influencing the development of a blanket handler. These include:

- i environmental factors, such as: radiation levels, elevated temperatures, and ultra-high vacuum compatibility
- ii architectural constraints such as access, mass, and the hardware geometry
- iii maintenance goals such as maintenance duration and total inventory, impacted by speed of movement, reliability of RM equipment, ability for recovery and rescue and number of systems required
- iv regulatory requirements such as design standards and the safety case

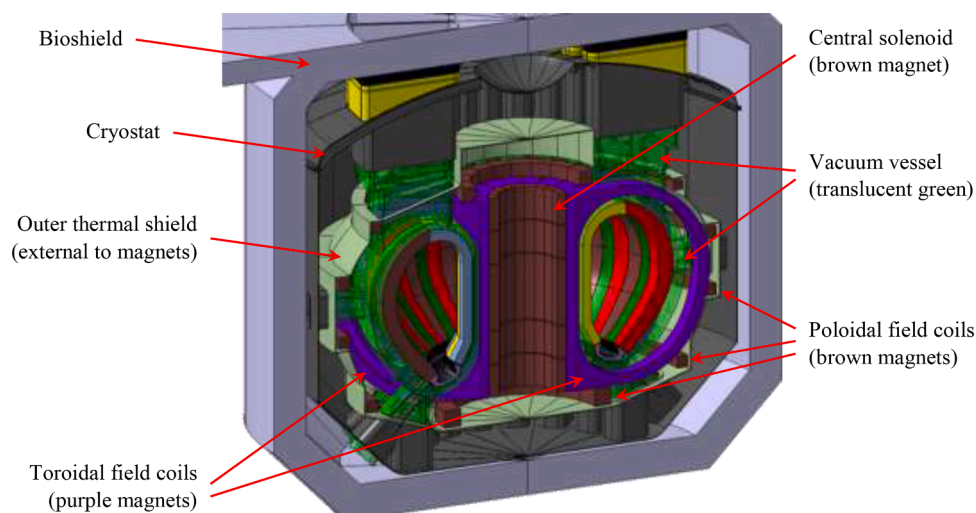
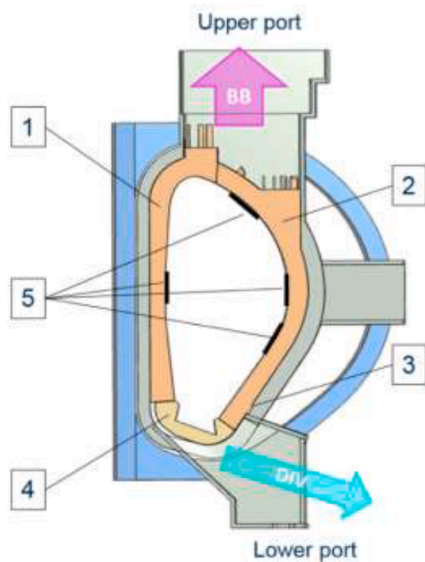

Fig. 4. Cross-section of DEMO within the bioshield.



1. Inboard Breeding Blanket (IBB): Segmented components that line the inner wall of the vacuum vessel. 2 per vessel sector. Require replacement several times during the life of DEMO. Length 12m. Mass up to 60 tonnes.
2. Outboard Breeding Blanket (OBB): As for the IBB but for the outer wall of the vacuum vessel and mass up to 80 tonnes. 3 per vessel sector.
3. Blanket to Vessel fixtures: Structural supports that mount the IBB/OBB to the vacuum vessel wall.
4. Divertor Cassette: Segmented components that line the bottom of the vacuum vessel. Require replacement several times during the life of DEMO. Length 3m. Mass up to 8 tonnes. 3 per vessel sector.
5. Limiters: Components to protect the BB. The highest replacement frequency, possibly every shut-down. Mass up to 7 tonnes.

Fig. 5. Key in-vessel components to be exchanged and their entry-egress routes

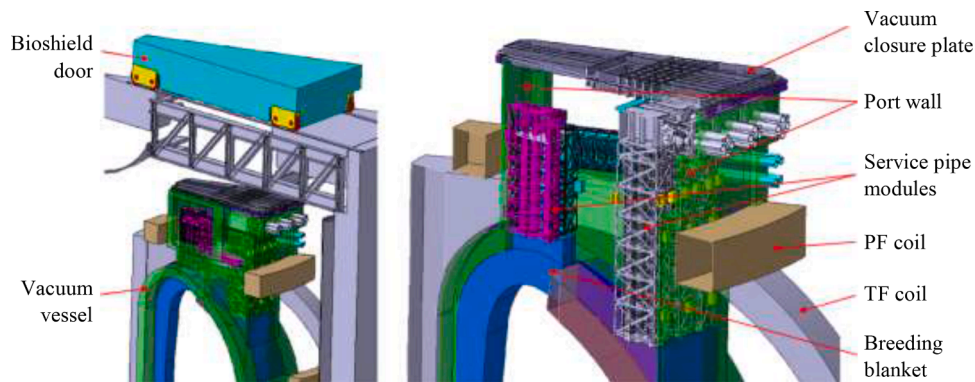

Fig. 6. DEMO upper port architecture from the 2017 proposal

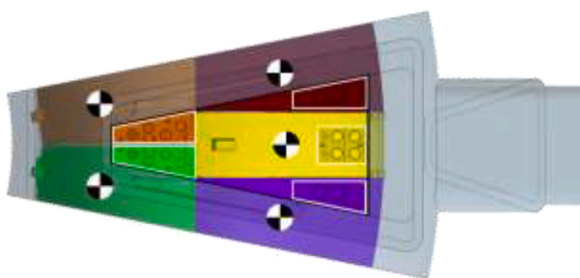

Fig. 7. Plan view on one sector (22.5°) of the vessel (grey), showing 5 blanket segments (coloured) together with their pipe connections and centres of mass relative to the port.

During the PCDDP, many blanket manipulator concepts were generated to investigate the bounds of the problem including:

- i a gantry crane with end-effector on a telescopic frame (Fig. 9)
- ii crane lifted counterbalance concepts (Fig. 10)
- iii a crane lifted in-line manipulator concept (Fig. 11)
- iv an end-effector mounted on a telescopic mast (Fig. 12)
- v a crane lifted hybrid kinematic mechanism (§ 3.2.2)

The gantry crane concept was not taken further because of handling

concerns relating to the heavy telescopic frame (~x223C60 tonnes) being part of the controlled motion and to the likelihood of high friction and backlash.

The counterbalance system concepts were not viable because they were too big to fit in the port due to the size of the counterweight (~x223C30 tonnes of tungsten, 6 m tall). Long beams (~x223C19 m) could be used to reduce the size, but these could not be operated in the space available and were not stiff enough to achieve the required blanket removal kinematics.

The in-line manipulator was not viable because the actuators and gearboxes required to achieve the very large torque output (~x223C2 MN.m) could not be packaged into the space available and the stiffness of the system was expected to be low, which would result in poor control characteristics.

The end-effector mounted on a telescopic mast was not taken further because the mast was too flexible to allow position control of the blankets (~x223C50 mm horizontal displacement when supporting a BB, resulting in ~x223C350 mm horizontal displacement at the bottom of the BB).

#### Hybrid Kinematic Mechanism

A Hybrid Kinematic Mechanism (HKM) was selected as the best solution to develop further due to its compact size and comparatively high stiffness. It is lowered by a crane and mounted rigidly to the Vacuum Closure Plate (VCP) as shown in Fig. 13. The HKM combines an upper

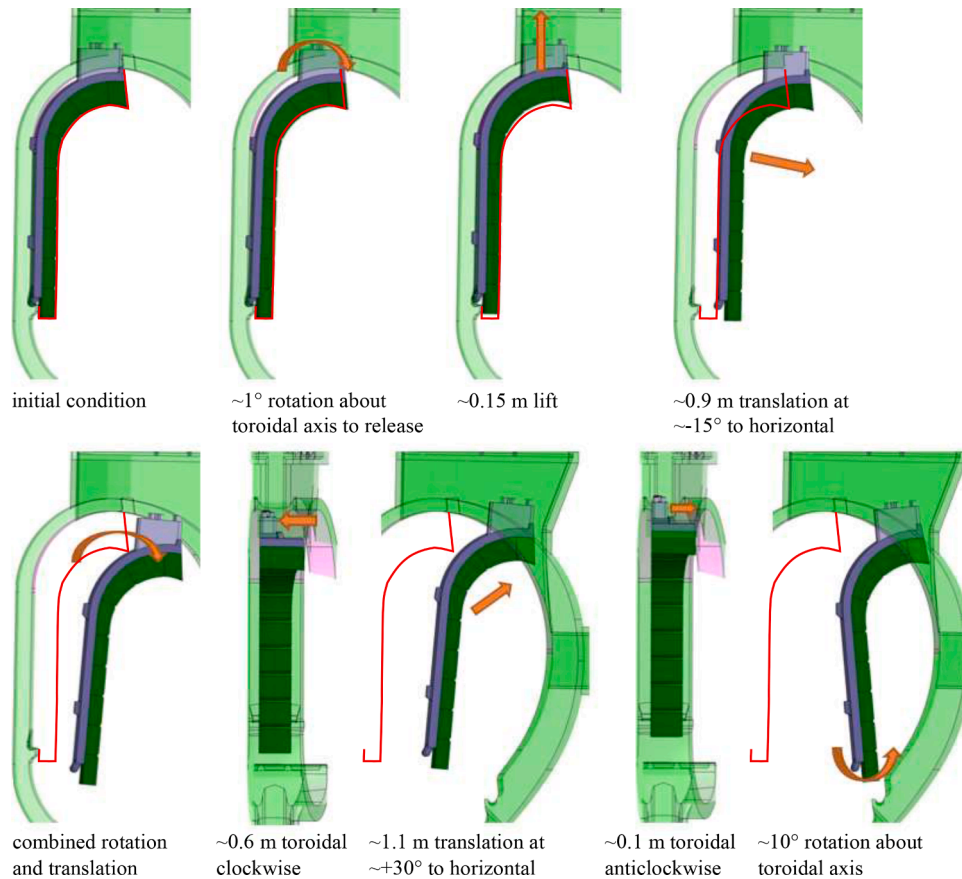

Fig. 8. Typical sequence of operations for Inner Breeding Blanket (IBB) removal, with adjacent blanket indicated in red outline

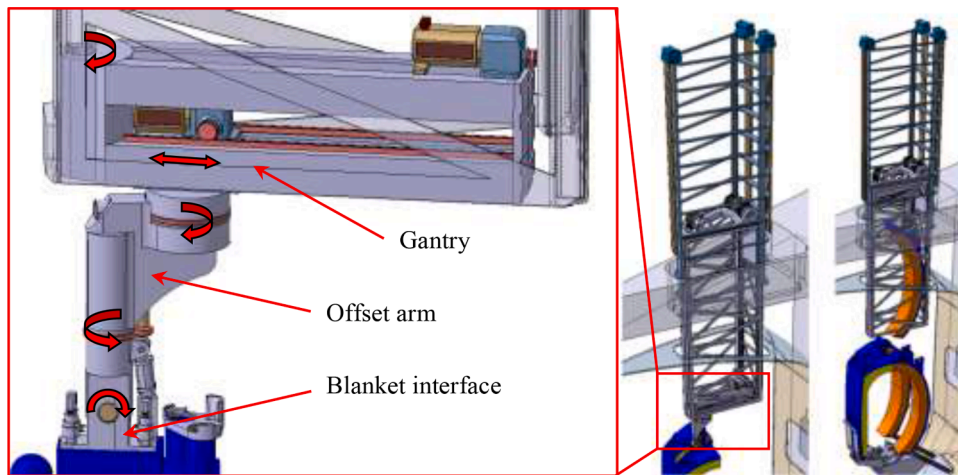

Fig. 9. Gantry crane with end-effector on a telescopic frame.

parallel jointed mechanism, providing the three linear degrees-of-freedom (DoF) (x, y & z) with a lower serial mechanism comprising three rotational axes (rot x, rot y & rot z) [6]. The HKM has an integrated plate providing a rigid platform when mounted in place of the VCP. This transfers the blanket manoeuvring loads to the vessel at the earliest opportunity to create a stiffer system. The HKM is ~x223C10 m in height with a total mass of ~x223C80 tonnes.

The mover connects to the upper back face of the blanket and operates within the relatively low-radiation environment (~x223C10 Gy/h) of the upper port. This allows greater freedom when selecting

electrical components such as motors and sensors, avoiding the need for bulky and heavy shielding panels, improving the overall reliability of the system, and allowing longer deployment durations.

The current DEMO architecture, with its long narrow ports, constrains all blanket handling solutions to be long slender mechanisms so they can reach the RM-blanket attachment interface and accommodate the joint travel required for the full range of blanket kinematics movements. The blankets cover the whole of the inside of the vessel so extend under the magnets, to the side of the port. This results in the blanket centre of gravity being offset from RM-blanket interface, so the blanket

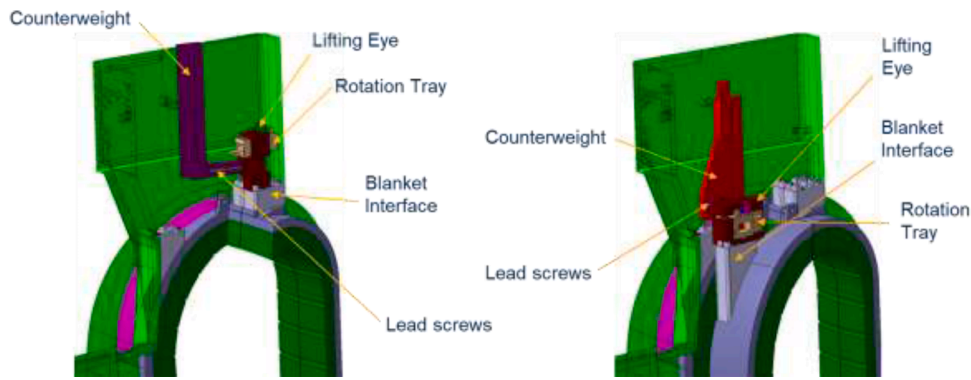

Fig. 10. Crane-lifted counterbalance concepts

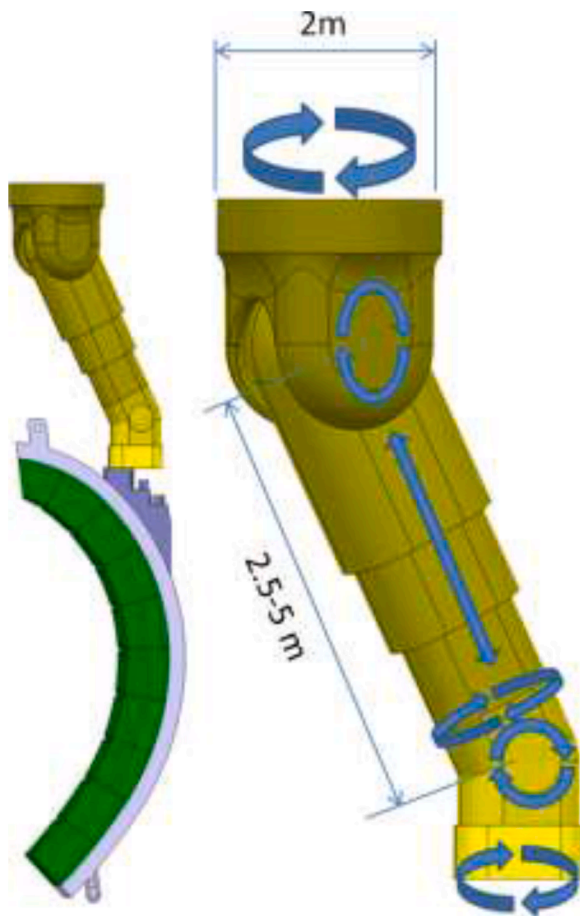

Fig. 11. Crane-lifted in-line manipulator concept.

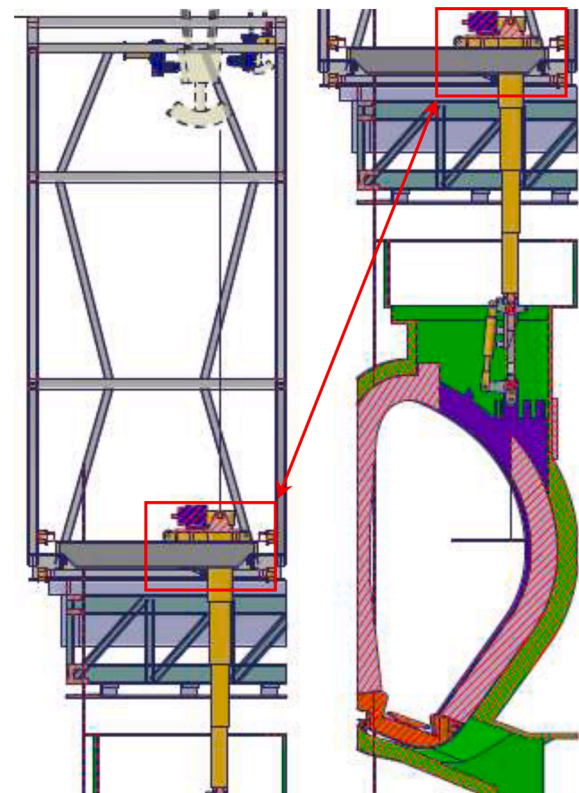

Fig. 12. End-effector mounted on a telescopic mast.

handler must be able to develop high moments, up to 1 MN.m. The architectural constraints make it challenging to package a mechanism capable of developing such torques and with adequate structural strength and stiffness, particularly in the case of lateral loads, within the confines of the port.

WPRM recognized that the BB handling system will need to be assessed as lifting equipment and meet requirements emerging from nuclear hazard analysis. WPRM carried out an initial assessment of the HKM to EN 13001 that included analysis of the design against the SL2 seismic design basis. This load case is beyond the capabilities of the HKM, highlighting the severe constraints that the DEMO architecture imposes on the BB handling system.

The HKM was also the subject of a keyword Hazard and Operability

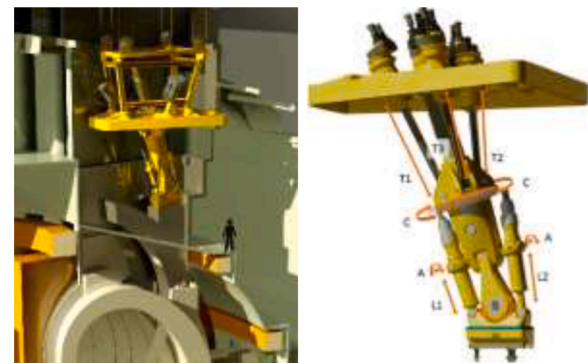

Fig. 13. Left: concept of HKM blanket mover operation (crane lift of HKM attached to Outboard Breeding Blanket segment); right: Detail of the six degrees-of-freedom of the HKM

Study (HAZOP) conducted by experienced industrial nuclear specialists. This study confirmed the need to keep the early design as simple as possible because complexity tends to hinder both reliability and safety. Features to enable recovery and rescue, or to meet specific safety functional requirements will inevitably add complexity. However, the complexity of the HKM design mainly emerges from the constraints imposed by the DEMO architecture. The HAZOP highlights this as a significant barrier to success.

The challenges related to the blanket handling were formally recognised in a design review which included external industrial experts [6]. Due to the high potential impact on plant and tokamak architecture a key design integration issue study was initiated on the breeding blanket vertical segment architecture [7]. The study considered a range of solutions, including split blanket options and a double-null solution in which there is a divertor at the top and bottom of the machine. Major progress was made in understanding the issues with the vertical segment-based architecture, but only limited maintenance strategy and design improvements were achieved, reinforcing the need for a project-based integrated DEMO design approach through the DEMO Central Team [8].

*Divertor handling*

Currently, there are 48 divertor cassettes are located at the bottom of the vacuum vessel and, like the blankets, they must be exchanged several times in the life of DEMO. Three cassettes are removed through each of the 16 lower ports by the Divertor Cassette Transporter. The centre cassette can be removed directly through the port whilst the cassettes on either side must be moved toroidally before removal through the port.

This maintenance strategy requires access to all divertor ports for maintenance and the removal of the divertor pipework from the port. There may also be other equipment that needs to be removed, including vacuum pumps mounted in some ports. There are then the options for these items to be either stored in the port cell and reinstalled, transported to the Active Maintenance Cell for storage, refurbishment and reinstallation, or disposal.

An alternative strategy is to have only a limited number of ports available for maintenance. In this case, a maintenance system would still be required for the replacement of pipes and equipment in the ports that might fail during operations, but it would mean these systems would be removed less often. In addition, a toroidal mover would be needed inside the vacuum vessel in the highest radiation areas to travel around the inside of the machine on an umbilical, delivering and aligning cassettes and pipework. This would add significant complexity to the maintenance system. It would require an autonomous in-vessel toroidal mover having the ability to be recovered or rescued. It would also be necessary to deploy and operate in-vessel tooling to remove the heat-affected-zone on the permanent pipes and to prepare the end of the pipe for welding, whilst capturing the swarf that would be generated.

The Divertor Cassette Transporter concept comprises three main components, the radial mover, the end-effector with cassette lifting platform, and the accessory equipment which includes the manipulator arm and tools. The initial design of the Divertor Cassette Transporter was based on handling the cassette from one end using an ITER-like cantilevered arrangement. Analysis of the available space in the lower port showed that a beam concept could be achieved, where the cassette is supported below its centre of gravity (Fig. 14), as was the case for the early ITER divertor design that was tested in the original Divertor Test Platform in Brasimone, Italy. This provided significant benefits through the reduction of the moment on the handling system and allowed a smaller, simpler transporter to be designed with smaller deflections.

The pre-concept design couples a drivetrain actuated radial mover and an integrated end-effector system with a rigid chain mechanism (Fig. 15). The beam concept coupled with the electric actuated rigid chain technology eliminates the need for hydraulics, resulting in a smaller, simpler maintenance system with reduced contamination issues

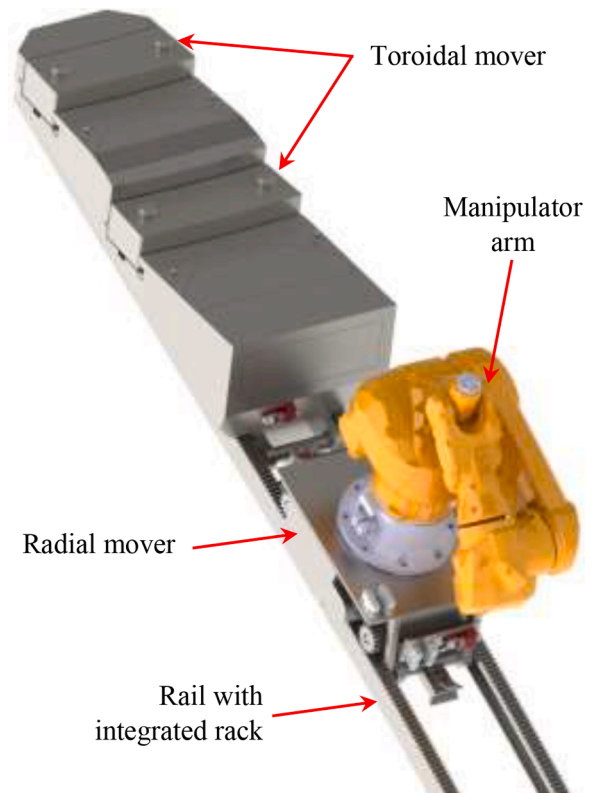

Fig. 15. Divertor Cassette Transporter.

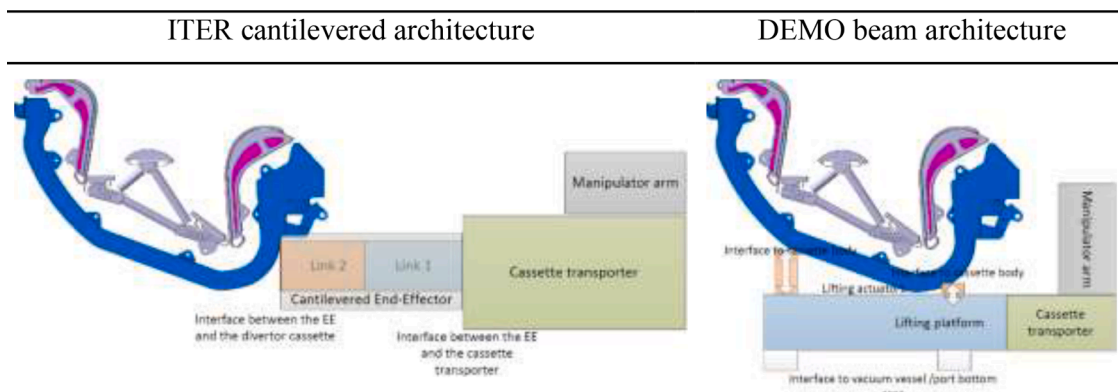

Fig. 14. Divertor transporter architecture comparison



and lower cost.

*Ex-vessel remote maintenance systems*

Ex-vessel maintenance includes the maintenance activities required in the area between the vacuum vessel and the Bioshield. In this area, radiation levels are very high, access routes are convoluted and complex, and there are significant limitations on the available space. This is because the bioshield and cryostat are expensive components with cost and complexity linked to size.

This is illustrated in Fig. 4, a cross-section of DEMO, indicating the in-bioshield magnets and containment structures which require inspection and maintenance.

Studies that examined the maintenance of in-bioshield components, performed accessibility assessments to guide plant designers as to where

to locate maintainable items, recommended modifications to designs to improve accessibility, and proposed generic movers, effectors and tools for the access, deployment, and operation of maintenance tools.

The rest of the ex-vessel area is outside the bioshield and is shown in Fig. 16. The CAD model was created to integrate the proposals made in separate ex-vessel maintenance studies. This provided an understanding of the cumulative impact of the maintenance design proposals on the overall plant architecture.

Principal features of the ex-vessel maintenance strategy proposals are:

- lowerRoman%1 Minimisation of the requirement for *in situ* maintenance, achieved through a strategy of line replaceable units. This helps reduce plant down time, the

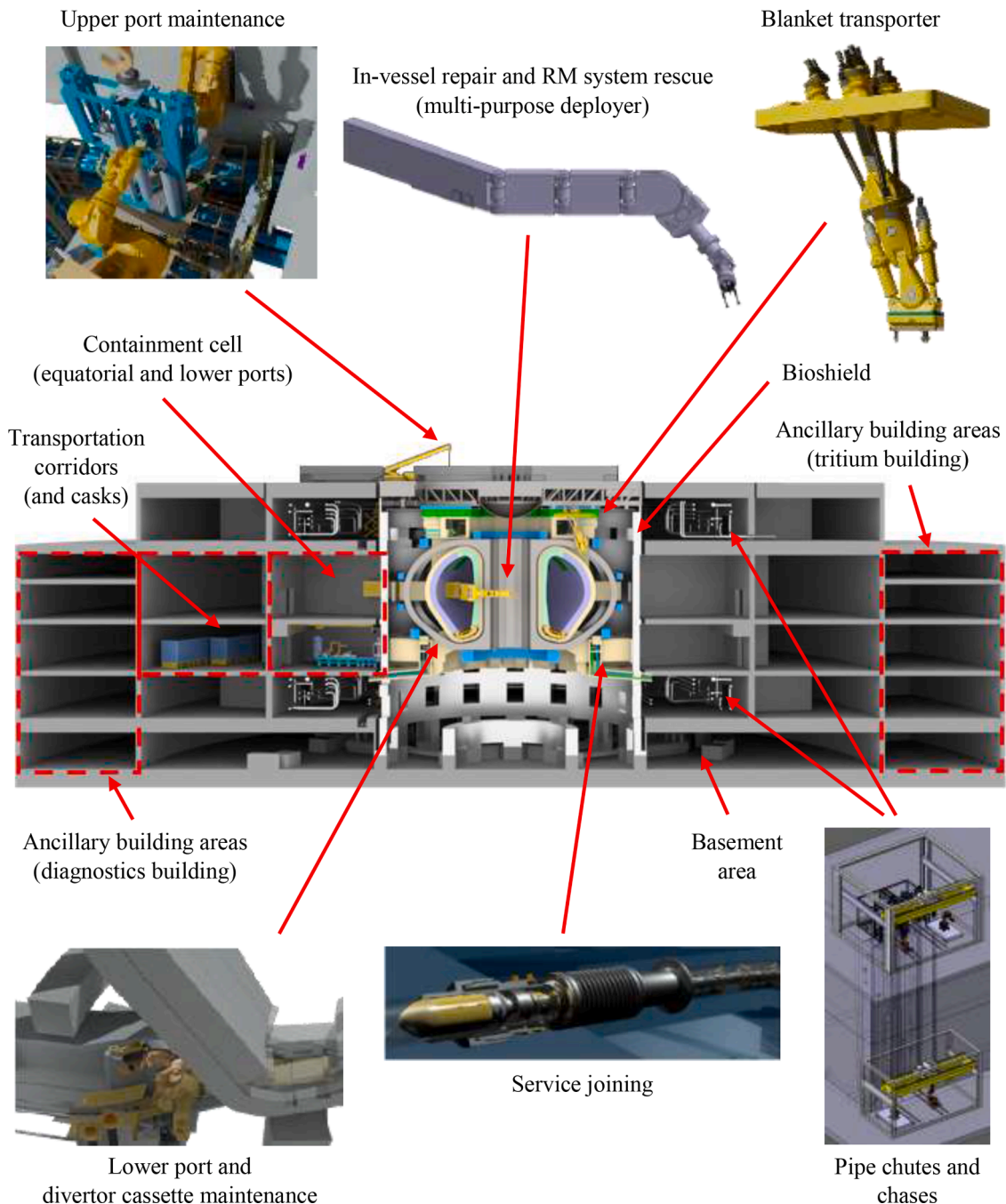

Fig. 16. Cross-section of DEMO reactor building concept accounting for remote maintenance space requirements (upper maintenance hall omitted for clarity)

complexity of maintenance operations, and the generation of contamination during maintenance operations.

- lowerRoman%1 Ground based omnidirectional cask transportation systems which are claimed as a layer of confinement for radioactive inventories. Ground based transportation is preferred due to the risk of dropped loads posed by overhead systems.
- lowerRoman%1 Building layouts that provide both the space and the supporting infrastructure to simplify maintenance operations (Fig. 17) [12]. This is achieved through:
  - a suitably sized containment cells
  - b standard overhead cranes
  - c shielded transportation corridors

Overhead transportation systems have been considered in early studies however later work recommends that such methods are avoided. The main reasons are:

- i the risk of dropped loads;
- ii more challenging rescue and recovery characteristics;
- iii the load is constrained to the operating area or path of the crane, reducing the range of possible options when considering the flow of materials around the site;
- iv confinement of contaminated items is simplified—overhead transportation of contaminated items from contaminated spaces such as containment cells into areas accessed by operators is seen as more complex; and
- v it is likely that overhead systems would have a shorter ‘range’ (the distance over which they are capable of transporting items).

The principal focus of ex-vessel studies was to determine the maintenance processes for power plant hardware which is expected to be maintained by primarily remote means, and potentially in an automated fashion. This represents a paradigm shift from the methods used to maintain fission power plants and has consequences for both the design of the maintenance equipment, which is expected to take the form of complex robotic systems, and the design of the power plant itself, which must be amenable to maintenance by such systems.

Operator access to the ex-vessel areas will be possible at certain times and therefore a hybrid maintenance approach will be necessary where plant is designed to be maintained remotely and manually.

Hands-on maintenance is undesirable under the ALARA (As Low As Reasonably Achievable) principle that applies both to individual operational exposures and the annual plant dose budget [5]. However, it can

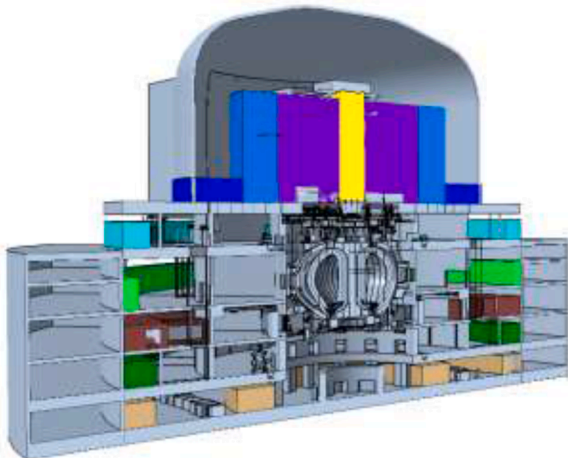

Fig. 17. DEMO space requirement analysis: maintenance volumes are shown as coloured blocks

sometimes be justified during for example:

- i unplanned corrective maintenance on the critical path to restarting the machine, where hands-on significantly reduces the downtime;
- ii recovery situations requiring the development of new maintenance systems; and
- iii infrequent low-dose maintenance operations that would otherwise require extensive, costly remote systems

#### Cask based maintenance

There are two approaches to cask-based maintenance, a ‘vessel cask’ approach where the vessel cask docks directly to the vessel and a ‘cell cask’ approach where there is a containment cell around the port to which cell casks are docked.

The vessel cask must contain all the RM equipment and power plant hardware required for a particular operation in a fully configured state (Fig. 18, left). Secondary containment is provided by a surrounding building or port cell.

In the cell cask approach, the RM equipment is deployed from the cell cask into the containment cell where it is configured for use before being deployed into the vacuum vessel (Fig. 18, right). This offers a more flexible maintenance configuration where recovery and rescue options are greatly increased. Some RM equipment could stay in the cell to further reduce the critical path maintenance duration, provided any cleaning or maintenance can be conducted in the cell, either remotely or hand-on once the cell has been decontaminated to an appropriate level. A prime example of where this might be the best approach is for the in-cell gantry crane which provides excellent transfer capability but is not suited to cask transfer. Other equipment should be outside the containment area but may need to be behind removable panels if maintenance access can only be made from within the cell.

For both approaches, secondary containment must be provided by the building or a surrounding structure (Fig. 18).

Lower port layouts were prepared to allow comparisons to be made between three options:

- i Large containment cell in which full maintenance systems can be configured and plant items can be stored that do not require maintenance prior to reinstallation.
- ii Small containment cell in which compact maintenance systems can be configured but all plant items must be transferred to the active maintenance facility prior to reinstallation.
- iii Vessel cask layout where maintenance systems and plant are delivered and returned to the active maintenance facility in a single cask.

The cell cask concept for the large containment cell approach was developed in more detail and this is shown in Fig. 19. Note the presence of infrastructure (a crane) within the containment cell, configured RM equipment immediately outside of the open port (top of the image, below the crane), the use of the cell to store items of power plant hardware which do not require maintenance when replacing divertors (vacuum pump, in the bottom of the image, left of centre) and the cell cask attached to the containment cell (bottom right).

The primary metric of interest for each option was maintenance duration, although estimates were made for the sizes of Cell Casks and Vessel Casks to allow the impact on building size to be determined. A selection of the results is shown in Fig. 20, normalised for the Large Port Cell option.

The preliminary results for these layouts show a 25% increase in duration for the small cell option and a 46% increase for the vessel cask option. The vessel cask also shows an increase in the number and volume of casks required but a significant reduction in the volume added to the vessel containment boundary.

Comparative analysis of the vessel cask and cell cask options continues during the early phase of the Conceptual Design Phase to:

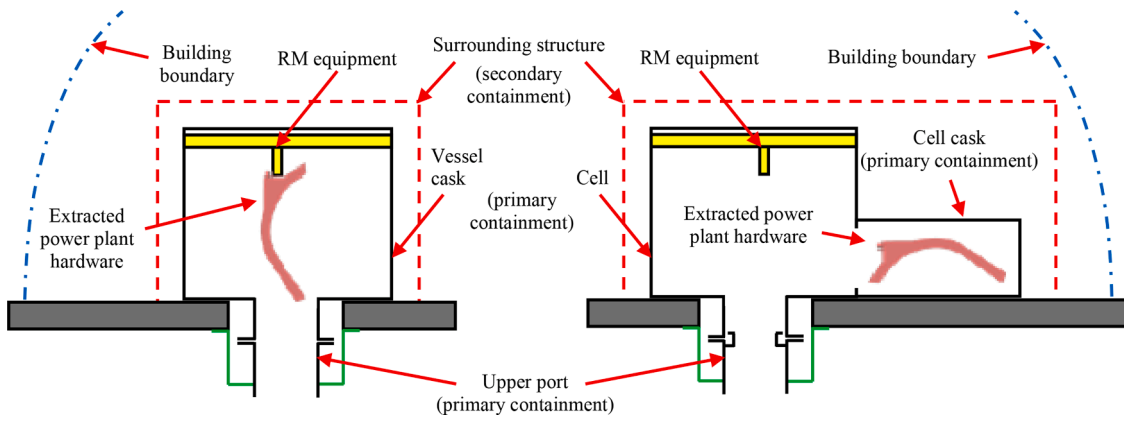

Fig. 18. Illustration of alternative confinement approaches: vessel cask (left), cell cask (right)



Fig. 19. Image of the large port cell approach for maintenance of the lower port

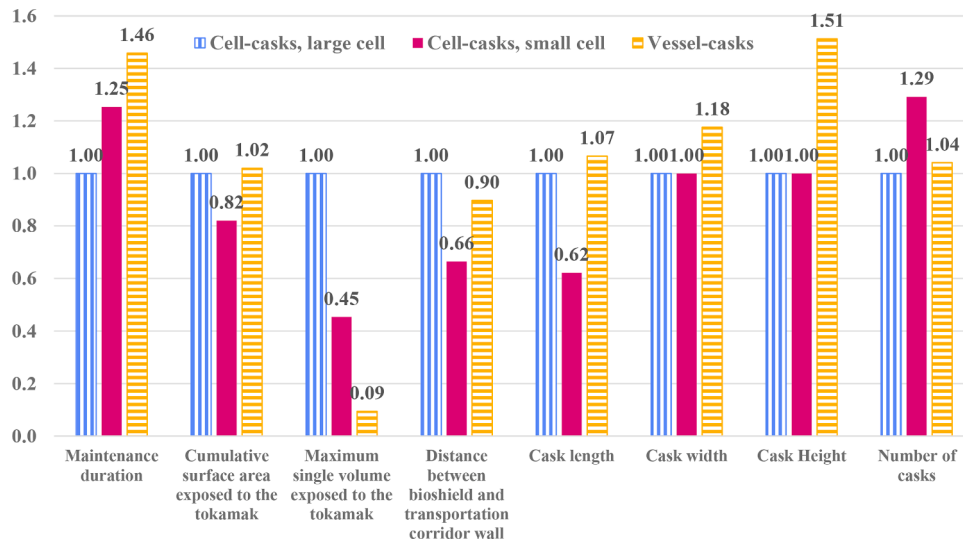

Fig. 20. Comparison of metrics for the large cell, small cell and the vessel cask approaches for the maintenance of the Lower Port.

i consider the upper ports as well as the lower ports  
 ii quantify the maintenance implications for the two options for metrics such as maintenance duration, number of casks and cost;

iii understand the space impacts for casks and for cells, including the effects on supporting and shielding structures, service connections and instrumentation; and

- iv determine the impact on the size of the tokamak building, a capital cost analogue.

Other plant areas investigated during the PCDP are listed below. In each case maintenance processes were determined based on implied high level maintenance requirements. Transportation, mover, and effector systems were also proposed which could provide the capability to perform the identified maintenance operations.

- Neutral beam cell
- Vertical pipe chutes
- Upper and lower pipe chases
- Basement area
- Lithium lead system

Contamination control to meet the safety requirements and ALARA principle are significant considerations for ex-vessel maintenance. The maintenance of DEMO requires the extraction and transportation of large, contaminated components, through large openings in the vacuum vessel. Both the open vacuum vessel and the extracted components will be sources of radioactive dust, and both will outgas tritium. These hazards must be contained within suitable structures.

Any viable solution must meet the mandatory safety and maintenance requirements. For example, the safety work package (WPSAE [5]) has specified a minimum of two layers of confinement must be placed around contaminated items where each layer must be capable of retaining its integrity in the event of foreseeable accident scenarios.

For all viable solutions there is a balance to be struck between what is the lowest cost approach for contamination control and ALARA (with minimized volumes) and what is the lowest cost approach for maintenance (with larger spaces available for maintenance system deployment and local storage).

Conclusions from the PCDP ex-vessel studies are:

- i Early engagement with the regulator will be instrumental in the granting of a license for DEMO. This will minimise investment in unacceptable solutions as well as the costs associated with retrofitting confinement measures that were not accounted for in the design of the plant.
- ii Items of power plant hardware should be decontaminated as far as practicable at the earliest point. For example, in-vessel components should be cleaned prior to extraction from the vacuum vessel and bagged or wrapped at the earliest opportunity. These measures will require the development of decontamination processes not yet considered by the project.
- iii The current DEMO architecture is too small to facilitate the maintenance required. In some cases, regardless of the maintenance approach selected. During the PCDP, no Ex-Vessel study concluded that the plant was sufficiently sized and contained sufficient infrastructure to support the proposed maintenance processes. This conclusion applies to the Containment Cells which are used to access the internals of the Tokamak as well as the transportation routes through which items are moved.
- iv The selection criteria to make a down-selection between vessel casks and cell casks is not agreed and the full data set not yet available for each port type. The most appropriate configuration of confinement when extracting, installing, and transporting components has therefore not been selected and this is urgent work to be continued in the concept design phase to identify the approach, considering issues such as cost, safety, maintenance duration, and risk.

#### Remote maintenance enabling technologies

The DEMO maintenance system has many differences to existing systems, driven by the need for power plant relevance, the size and mass of components and the harsh environment. These lead to the requirement for novel technologies or the novel application of existing

technologies. Critical novel technologies, those required to enable the maintenance strategy, present a high risk to DEMO due to the large impact on the design if they cannot be made to operate as assumed.

This section describes the development of these technologies to mitigate the design risk. The highest risk technologies were identified as:

- i Contamination control
- ii Service joining: welding, mechanical connections, and pipe alignment
- iii Blanket handling: control system and automation
- iv Radiation hardened systems, particularly for operations in-vessel.

#### Contamination control technology

WPRM developed a contamination control door (CCD) concept. The CCD serves as the interface between separable containments (e.g. vacuum vessel and vessel cask) to assure the safe movement of contaminated components between them (i.e. to inhibit uncontrolled release of contamination). The remotely operated CCD, technically a double door system, is made of two separable doors and three locking mechanisms. In Fig. 21 the cask door is connected to the cask and the port door is connected to the VV upper port duct.

A proof-of-principle test rig was developed, constructed, and operated to evaluate the performance of the high-risk components of the CCD. The tests established the feasibility of the CCD concept and helped to quantify its limitations.

#### Service joining strategy

Reliable service joining systems are key to an effective maintenance system due to the high number of safety critical joints. In the scenario investigated by WPRM, there are 752 remote pipe connections required for the blankets and divertors. The main factors to be considered during development are:

- Space constraints: competition for space is inherent to the DEMO plant architecture
- Operating environment: temperature range, high radiation, varied service media
- Reusability: considering radiation effects on seals and materials
- Joint preparation: using remote tools rather than direct operator skill and dexterity
- Joint alignment: remotely achieving tight tolerances and against large forces
- Joint processes: including heat and surface treatment and testing after the joining

These factors translate into a need for efficient and reliable joining systems that meet defined quality standards.

The service joining strategy adopted during the PCDP focused on

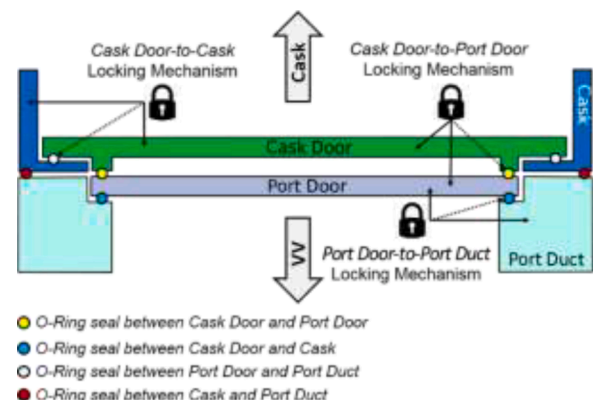

Fig. 21. Contamination Control Door (CCD) concept applied to a vessel cask

cutting and welding processes, and mechanical connections. WPRM approached the task by studying the pre-concept services design for the breeding blankets and divertors, which were identified as bounding cases. From this set of requirements, technology concepts were developed with involvement from industry.

The connections close to the breeding blankets and divertor cassettes are expected to be welded from within the bore because the limited space between pipes prevents the use of external orbital welding and the flanges required for mechanical connections. Where mechanical connections can be proven to provide the necessary performance under the DEMO operating conditions and within the space available, they should be preferred as the connection time is likely to be much faster.

From a review of available technologies and commercial solutions, WPRM identified where effort should be spent on novel enabling technologies. WPRM developed concepts incorporating these technologies and validated them through ‘proof-of-principle’ trials capturing key functionality.

The trials were carried out using two standard pipe sizes close to the smallest and largest pipe sizes proposed in the DEMO plant designs. These were NPS 3.5 (DN90) schedule 40 and NPS 8 (DN200) schedule 80. The tool designs are challenged by the internal diameter of the small pipe (DN90) and the wall thickness of the large pipe (schedule 80).

#### Laser cutting and welding

The drive to reduce plant downtime motivated the exploration of laser processes for rapid cutting and welding but this raised several challenges:

- Space to package optics and cooling
- Precise alignment required for laser welding
- Protection of the optics at the weld site (splatter, weld plume)
- Deploying the tool and identifying the weld site

During the testing campaign, 24 laser cuts and 55 welds were made in steel materials representative of those anticipated for DEMO: ASTM A240 grade 316L and ASTM A355 grade P91 (used as a substitute for EUROFER 97) Fig. 22.

Cuts of 5 mm pipe and welds in 3 mm pipe were achieved [9]. Cuts were achieved in 34 seconds using a power of 1.3 kW. Welds were achieved in 25 seconds using a power of 2.4 kW and a linear speed equivalent of 500 mm/minute, 5 times faster than a typical TIG welding speed of 100 mm/minute. For both cutting and welding, heat management and debris damage were found to be problematic. Work is underway in the Concept Design Phase (CDP) to manage debris more effectively and increase the reliability of the weld. While the welds achieved were not fully compliant with the relevant ISO standards [10], the results were promising given the maturity of the technology. This provides confidence that the technique can be made viable for DEMO [11].

Further work is needed in the following areas:

- Study of cut quality and the management debris—the acceptability criteria for cutting debris need to be defined.



Fig. 22. Laser cutting tool (left) and welding tool (right) both with samples in P91 and 316L

- Development of the power handling capability of the welding optics in-bore: 2.4 kW allowed a 3 mm thick weld to be produced. Increasing the power to 5 kW will allow optimisation of welding parameters.
- Development and validation of the techniques for large bore pipes.
- Development of control techniques for optimization of the weld to achieve standards compliance, and qualification for use on DEMO.

#### Laser tool deployment and integrated testing

During design and testing of laser tool deployment systems, WPRM found that a drive system based on in-pipe tractor units would be infeasible. Although a tractor unit was built and tested (Fig. 23) it was found to be incapable of providing the minimum tractive effort required to overcome obstacles in the pipe. Testing identified a minimum requirement of at least 210 N, whereas the unit had a capability of 130 N. Several tractor units would be required to provide sufficient force to drive the tool to the operating location, and this would make the tool excessively long. The ‘train’ of tool, positioning sensors, and drive system shown in Fig. 23 is already 1300 mm in length, with the tool contributing 580 mm.

Through testing, WPRM found that a deployment system based on pushrods, where the tool is driven to location from a pipe stub, could be effective. The testing revealed the following key challenges, which are relevant to all remote handling equipment:

- Feedback –comprehensive feedback is needed to determine the status of the equipment and diagnose any issues, but this leads to a more complicated and less reliable tool.
- Reliability – failure modes must be carefully mitigated in the design to prevent loss of the tool or the plant on which it is operating.

#### Mechanical connections

Mechanical connections offer the potential for rapid remote maintenance of service pipes. Work in this technology area focused on delivering a solution for a multi-pipe mechanical joint (Fig. 24). WPRM developed a design that accommodates several DN90 and DN200 pipes. Simultaneous connection of several pipes reduces the time required for maintenance given the large number of pipes that need to be disconnected in DEMO. Working with industry, WPRM identified the following challenges:



Fig. 23. In-bore tool deployment system using a tractor unit

- Extremely high sealing loads, in the order of several meganewtons are required for a multi-pipe connector to achieve helium leak-tightness for the DEMO operating temperature and pressure
- Large tooling required to develop the sealing loads
- No seal has been qualified for the combination of operating conditions of high pressure (96 bar), high temperatures (550°C) and extremely low leakage rate ( $10^{-9}$  mbar.l/s) for a difficult medium to seal, in the case of helium pipework.
- For pipework carrying lithium-lead, residue could prevent separation of the joint.
- Reusability and high temperature creep under the operating conditions.
- Non-destructive testing to verify seal integrity is challenging because of the large number of seals to be tested.

Two conceptual designs for a suitable Mechanical Pipe Connector (MPC) have been developed, achieving the requirement for even application of the large sealing force.

The Finite Element analysis shown in Fig. 25 for concept design 2 confirms that the high sealing loads also prove structurally challenging. Even with large cross sections of solid material, the clamps are subjected to continuous high stress. This effect is even stronger for the connecting bolts where the mechanical stress is close to the yield strength of the material used ( $1.4903 \times 10\text{CrMoVNb9-1}$ ) at 550°C. It is also important to note that this material has the highest yield strength at 550°C (270 N/mm<sup>2</sup>) of all pressure vessel certified steels.

A proof-of-principle experiment has been developed for concept design 2 (Fig. 26). The tests will be performed under DEMO operating conditions of pressure and temperature.

#### Pipe alignment

The development of feasible pipe alignment systems for DEMO is also a key challenge. Passive alignment is desirable, but this may not be possible for the high alignment forces due to thick-walled piping and misalignment over long pipe lengths. Pipe systems can include bellows to reduce these forces, but bellows have higher failure rates than the pipe.

A passive alignment system was designed, and a proof-of-principle test conducted to align a group of two NB200 pipes and one NB90 pipe (Fig. 27). The misalignment created in the assembly due to manufacturing tolerances was 0.92 mm, requiring a force of 10000 N to bring the weld faces into alignment.

The main lessons WPRM learned from this test were:

- Flexible elements still have high stiffness (1000 N/mm for a DN200 element)
- The alignment mechanism geometry is critical to operation

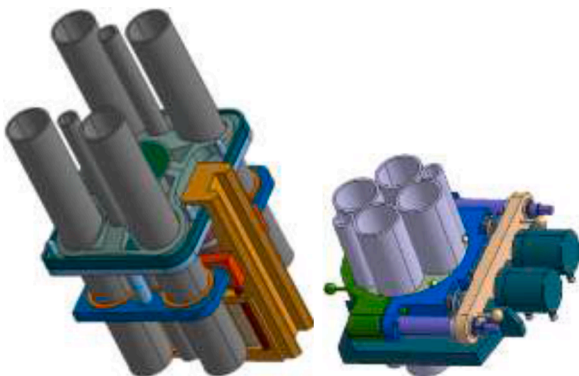

Fig. 24. –Mechanical Pipe Connector designs: concept design 1 (left), concept design 2 (right).

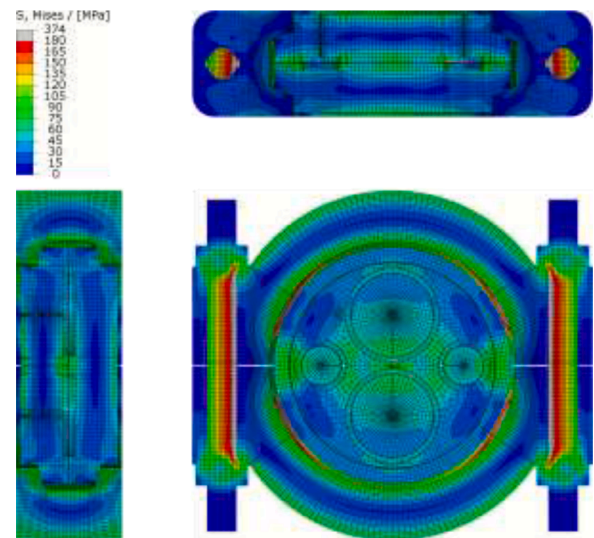

Fig. 25. Finite Element study of MPC concept design 2. Mid-plane equivalent stress distributions at 550°C and 96 bar (third angle view).

Further work is needed to optimise the alignment geometry and thereby define the space required and the maximum misalignment forces that can be accommodated.

#### Active Positional Control System

The blanket segments are required to be accurately positioned within the vessel. The current target is  $\pm 5$  mm. This means the RM equipment needs high positional accuracy, proximity feedback and suitable vessel features to enable this. The environmental conditions encountered, combined with the deflections and distortions of the RM equipment and hardware necessitate the need for a developed control system to achieve the accuracy required. In addition, the control system will need to be able to respond to the dynamic inputs from the payload with adequate bandwidth in the actuated joint drivetrains to attain the movement speeds required to keep maintenance duration times to a minimum.

Analysis of the blankets and their movers shows that the system dynamics cannot be ignored if the exchange is to proceed at an acceptable speed as the only option would be to wait until the kinetic energy of every move has fully dissipated before the next move is started. There are no known parallels for single connection point manoeuvring of a non-rigid 80 tonne payload with a non-rigid 70 tonne manipulator and this must be done through a complex kinematic path with small clearances.

Additionally, the initial action of removal is to break the adhesion that may have formed during the high temperature, high vacuum, and high radiation operational campaign. Load transfer of the blanket mass from the vessel to the handling system will be a particular challenge for this system.

For these reasons WPRM initiated a programme of development on an Adaptive Position Control System, capable of responding automatically and safely to unwanted movements in the load, considering the full dynamics of the mover and payload. Control adaptation will be necessary to compensate for the non-linearities and the considerable uncertainties in the dynamics. Since this is largely an energy dissipation problem, the currently favoured methodology is based on passivity theory. Conventional linear systems theory, which is based on a lumped parameter paradigm, is not appropriate for a distributed non-linear system with many possible vibrational modes.

In the case of blanket handling, there will be a very limited number of sensors able to measure the in-vessel operations and the performance of conventional cameras will degrade rapidly with exposure to radiation. The concomitant requirement of artificial lighting would also be cumbersome.

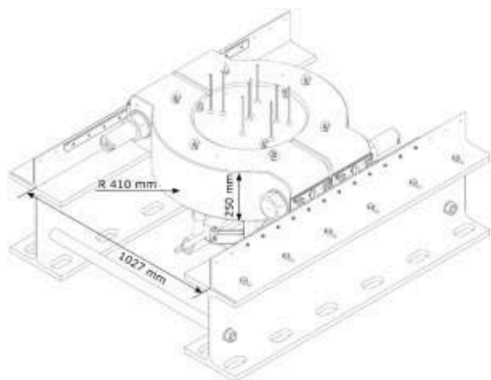

Fig. 26. Mechanical Pipe Connector proof-of-principle test bench isometric views

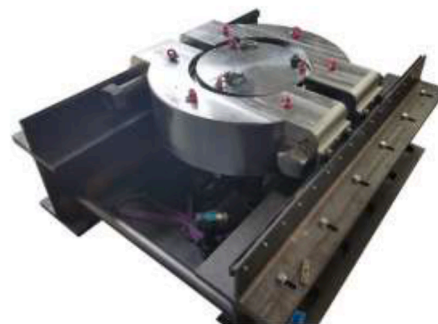

Fig. 27. Passive alignment mechanism testing showing pipe module dead-weight simulant at right

#### Telescopic Articulated Remote Mast - TARM

The TARM is a large manipulator system built in the 1990s for anticipated high dose ex-vessel operations on the Joint European Torus (JET), but it was rarely used. It can deploy a twin arm servo manipulator, mounted to the end. The TARM system has been refurbished and installed on a new stillage in the RACE facility in UKAEA (Fig. 28). At the end of the PCDP, commissioning was almost complete.

TARM will be used as an operator training platform and for conducting integrated tests, where tool testing can include remote deployment.

TARM is also being used to test the Adaptive Position Control System

(§3.4.7). The load is represented as flexible pendulum with a mass at P pivoted at H which can be actuated by a linear motor A (Fig. 29). The fastening at H can be loose or fixed. The entire assembly is attached to the TARM using the standard JET boom coupling ring shown at F.

The Adaptive Position Control System (APCS) monitors the position of the flexible load by means of a stereo camera system mounted to the TARM. APCS has no control of the linear actuator and has no *a priori* knowledge of the dynamics of the flexible pendulum.

The TARM and its flexible payload are not intended as scalable proxies for a high-mass handling system. However, the test rig will generate evidence to inform safe handling speeds and safe transfer to another mover where a human operator has no direct feedback, i.e. where conventional operator-in-the-loop approaches fall down. The rig is also expected to confirm that automated remote maintenance is needed where there is no direct line-of-sight.

#### Automation technologies – inspection and maintenance

Whereas the need for automatic position control of flexible payloads is anticipated, the need for automated inspection a near certainty. The scale of DEMO, combined with its mission to demonstrate reliable fusion power-plant technology, leads to the realization that reliance on manual inspection will not be credible.

WPRM considered two automation technologies relevant to DEMO during the PCDP: tile anomaly detection (inspection) and tile replacement. WPRM used the automated inspection and maintenance test unit (AIM-TU) robot cell, built specifically to support automated maintenance research in DEMO.

The automated inspection tests showed that automated detection of anomalies using commercial-off-the-shelf (COTS) systems is feasible but may require higher levels of (artificial) intelligence if it is to be widely applied across the entire DEMO plant. As with all RM systems, radiation tolerance must be considered, and this will be particularly challenging where the radiation levels are highest, in-vessel.

The automated maintenance tests showed that automation was much faster than the same operations that were carried out on JET using human-in-the-loop teleoperation. However, it also showed that issues arising during automated operations could easily reverse this and that most of the issues stemmed from applying COTS equipment in subtly different ways to their original design intent.

The automated maintenance tests used two robots, one with red strips and the other with green strips (Fig. 30) deployed in tandem. The red robot was tasked with handling tiles (damaged and new); the green robot was tasked with unfastening and refastening the screws holding tiles in place (Fig. 30). A tile replacement sequence was repeated 20 times under test conditions to assess system robustness. 18 cycles were successful. Two failed due to the tile orientation being incorrectly determined by the camera during collection.

The inspection and replacement techniques were combined in an integrated test. Here, the robots first scanned the tiles, identified any



Fig. 28. Refurbished TARM installed on a bespoke remote maintenance testing stillage at UKAEA.

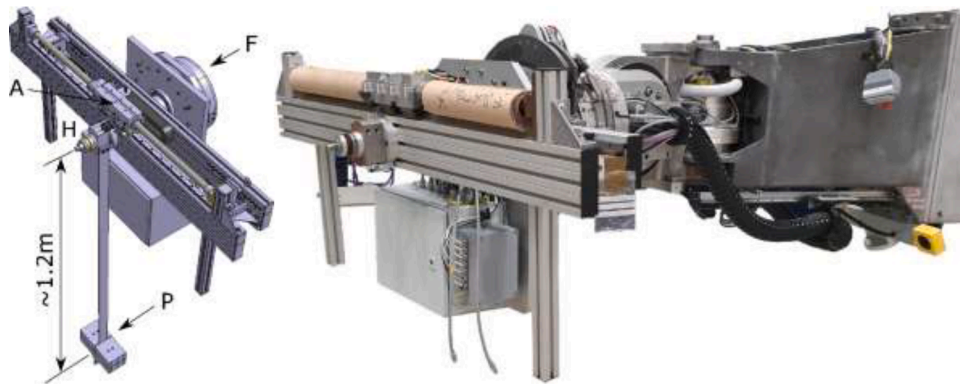

Fig. 29. Left: flexible pendulum model used to validate APCS; right: partial installation of flexible pendulum on TARM

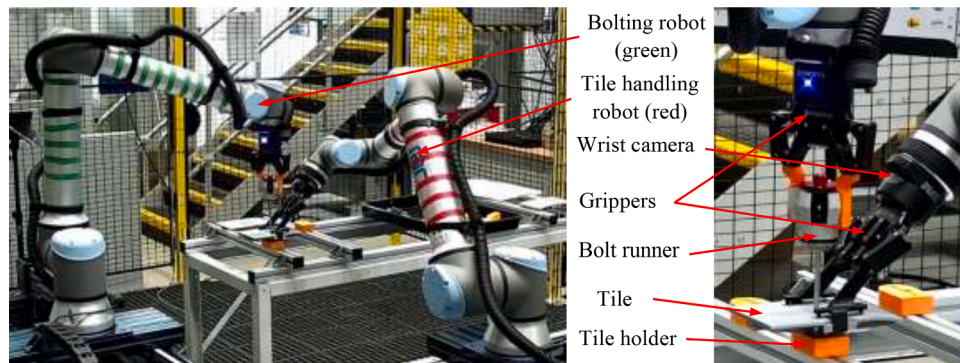

Fig. 30. Automated tile replacement

anomalies, and then replaced only the faulty tiles. The task was only completed successfully in 3 out of 5 attempts under test conditions, despite the high reliability of individual subtasks (anomaly detection, tile pick-up, tile bolting, etc.).

The testing demonstrated the preliminary feasibility of automated tile replacement using commercial-off-the-shelf (COTS) equipment under test conditions. However, it also showed that achieving the necessary robustness requires significant effort, especially as the spectrum of subtasks required to achieve the goal increases. While most of the barriers to automation can be overcome, it reinforces the importance of using equipment well-suited to the task, and of carefully defining the task itself.

Further work should explore new digital engineering approaches to iterative concept design of automated systems, and build on the demonstration work started on AIM-TU.

#### Digital twin

Digital twins can help to support the planning, design, and development phase of DEMO by simulating and finally quantifying the direct impact of the design of equipment, component, system, or structure on the overall maintenance procedure. They also offer advantages during operations by processing real physical data via simulations to give suggestions and predictions in real time to derive optimal decisions for maintenance related procedures (Fig. 31).

WPRM has already developed a concept level implementation of an intralogistics and maintenance digital twin for DEMO [14]. The main characteristics of a maintenance digital twin comprise the ability to predict the maintenance duration, real-time transfer of physical data, real time simulations, and the integrated control and optimization of maintenance procedures in real time. As a result, the application of a maintenance digital twin can lead to increased operability, reliability, and safety in general by reducing failures and increasing the localization

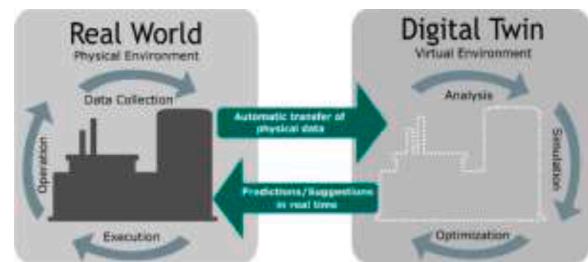

Fig. 31. General principle of a digital twin [14]

of failures.

For more detailed information about the application of a maintenance digital twin at DEMO see [14]. Different digital twin concepts and respective requirements have been introduced and the benefits of selected digitalization strategies in the context of digital twins have been shown.

#### Remote Maintenance Test Facilities

The technical risks identified in the PCDP require mitigation to an appropriate level during the Concept Design Phase to facilitate the Engineering Design Phase. One of the first tasks of the Concept Design Phase is therefore to identify the most critical technologies and the testing needed to provide effective risk mitigation, so that test facilities can be specified and built on a short timescale.

While most of the investment in test facilities will be made during the engineering design phase, several smaller facilities are under consideration for construction during the CDP by an expert panel.

The panel is tasked with assessing whether the RM test rig options under consideration meet the design needs, whether the purpose of the tests is sound and whether the performance satisfies the usability and



flexibility needs for future development.

The assessment will consider:

- i the greatest risks of the DEMO design for remote maintenance;
- ii the impact of the nuclear environment constraints and in particular the need to find technical solutions that minimize the spread of radioactivity and contamination;
- iii the impact of the uncertainties still affecting the design of the in-vessel components (e.g. breeding blanket and divertor and their structural and services connections to the rest of the device) together with the need to keep sufficient flexibility to accommodate possible design evolution; and
- iv the Return of eXperience (RoX) of ITER with regard to RM testing and risks.

#### G1 Gate Review

The WPRM activities were reviewed by a panel of external experts as part of the G1 Gate review [15]. The panel report made the following comment and specific recommendation:

*Because of the deep impact in determining the availability factor of a fusion power plant, the priority has to be the development of a remote maintenance strategy that can lead to a reduced duration of a maintenance outage while adhering to safety requirements.*

*No viable solution has been identified for maintaining the breeding blanket segments remotely. This will require modification at the plant system level, the component level, and the remote maintenance tooling.*

*Resolving the remote maintenance issues is on the critical path for the DEMO concept design. Remote maintenance needs to be addressed as part of the entire plant and the individual components from the very beginning with the leadership of the DEMO Central Team.*

Since the review, planning for the Concept Design Phase has focused on development of new strategies for the maintenance of the blanket and the integration between the Remote Maintenance work package, the DEMO Central Team and the plant designers to enable the development of a viable solution with minimum duration that meets the safety requirements.

#### Conclusions, lessons learned and recommendations for future work

##### Maintenance architecture

Remote maintainability of the DEMO plant is a critical goal in the roadmap to fusion. We can only reach this goal collectively because remote maintenance systems are only effective if the plant has been designed for maintenance compatibility. Therefore, remote maintenance requirements contribute to the constraints and definition of the plant, including its overall size and topology, and must be considered from the outset of the plant design.

The proposed PCDP architecture is challenging for maintenance of the plasma facing components due to the challenging environment and the following handling system factors:

- i Long narrow access ports due to
  - a the magnetic cage
  - b thick shielding
- ii Large heavy components due to the need to
  - a minimise the number of components to maintain
  - b perform handling operations from the ports where radiation levels are lower

It results in a handling challenge that has not previously been tackled, one where both the load and the handling system are flexible, and the load requires dexterous handling in all six degrees of freedom.

One of the key strategies for the PCDP was to have access through all the upper and lower ports for maintenance of the blankets and divertor.

This allowed most of the maintenance to be conducted from within the ports and mitigated the risks associated with the need to install toroidal movers within the vessel to collect the blanket segments or divertor cassettes and bring them to the port for extraction.

The need for a project-based, integrated DEMO design, was identified as critical through the work undertaken in the PCDP. This was also recommended in reviews by independent Remote Maintenance experts and was endorsed by the G1 review. During the next phase, WPRM will help to identify and prioritize integration efforts and allocate resources to these as required by the DEMO project.

Work in the PCDP started to provide the data required to assess the cost and performance balance between the plant and the remote maintenance systems. Further work to clarify this will form a significant part of the Concept Design Phase.

Modifications to the plant design to increase the available space for handling systems will be explored in the Concept Design Phase, with a view to increasing maintenance efficiency, thereby reducing the overall lifecycle cost of DEMO. As part of this work, the positive effects will be balanced against design and capital costs.

##### In-vessel maintenance

The blanket handling system designs have shown that the inboard blankets provide the largest challenge. The payload moments are very high and the first inboard blanket needs to be passed under its neighbour before it can be moved below the port for extraction.

A range of blanket handling system designs have shown similar limitations in structural strength (particularly during a seismic event), stiffness, and friction. These lead to challenges for control and packaging of mechanical components, all driven by the limited space in the vessel and the port.

The divertor handling system design has significantly improved during the PCDP by the addition of space between the bottom of the divertor and the vessel which allows the handling system to lift the divertor cassettes from below their centre of gravity, eliminating the large moment, reducing the size of the handling system and the deflection of the load.

Work in the Concept Design Phase will consider new solutions—such as two-port blanket handling (from the top and the bottom), alternative blanket segmentation, and replacing just the plasma facing armour—and will quantify the benefits of new tokamak architectures. Additional efforts will be made to ensure that Remote maintenance is considered alongside other performance requirements when the DEMO plant architecture is reassessed.

##### Ex-vessel maintenance

Ex-vessel maintenance can significantly affect both operational costs, which rise with the number of casks to be moved, cleaned, and stored, and the capital costs, which are affected by the plant layout needed to provide access to the transport systems. In the Concept Design Phase, studies to address both these aspects will intensify.

One of the more significant maintenance options investigated during the PCDP is the use of port cells. Compared to vessel casks where all the systems must be configured and deployed from the cask, these provide a relatively large space for the assembly and deployment of maintenance systems, and for recovery and rescue. In the Concept Design Phase, WPRM will collaborate in DEMO wide studies to define the confinement philosophies, leading to practical containment system architectures that clarify the design direction.

The ability to recover maintenance systems following any credible failure scenario can have a large influence on the selection of maintenance systems. An understanding the failure modes and recovery strategies building on earlier work [13] will be developed during the Concept Design Phase.

## Enabling technologies

The work in the PCDP identified the blanket handling control system and the service joining as the highest risk novel maintenance system enabling technologies.

During the PCDP, technology development was undertaken on an Adaptive Position Control System that will be capable of responding automatically and safely to unwanted movements in the load, considering the full dynamics of the mover and payload. The TARM manipulator system was refurbished to enable initial testing of the control system.

For accurate positioning, the blanket handling control system relies on the development of a structural simulator to predict the static and dynamic deflections of the mover and payload. This simulator will also help to speed up the mover design development through rapid assessment of the dynamic performance. This work will continue during the Concept Design Phase and is expected to confirm that automated remote maintenance remains the fastest and safest option where there is no direct line-of-sight available for human-in-the-loop operations.

Early feasibility tests have been undertaken on the DEMO AIM-TU robot cell. Anomaly detection and reactor tile replacement tasks have been successfully automated using commercial-of-the-shelf equipment. When compared to equivalent tasks performed by JET teleoperators, the systems were able to complete tasks faster. The results are an early sign of the feasibility of automated maintenance. The testing has also highlighted that significant work remains to develop systems that are sufficiently robust for real deployment, and this effort will continue during the Concept Design Phase.

Laser bore cutting and welding was selected during the PCDP as a potentially highly beneficial technology due to its speed and non-contact nature but packaging laser optics, cooling and sensors into the smaller pipe sizes was novel. Proof-of-principle testing during the PCDP has shown that pipes can be cut and that suitable weld forms can be produced in pipe sizes down to 90 mm bore with a 5 mm wall. Further testing for larger pipes with thicker walls is planned for the Concept Design Phase. Mechanical connections and pipe alignment are also critical enabling technologies that are planned for further development during the Concept Design Phase [Fig. 22](#).

## CRedit authorship contribution statement

**Oliver Crofts:** Writing – original draft. **Antony Loving:** Project administration, Supervision, Resources. **Marc Torrance:** Writing – original draft, Visualization. **Stuart Budden:** Writing – original draft, Investigation. **Ben Drumm:** Writing – original draft, Investigation. **Tristan Tremethick:** Writing – original draft, Investigation. **Didier Chauvin:** Validation, Writing – review & editing. **Mikko Siuko:** Project administration, Writing – review & editing. **William Brace:** Project administration, Writing – review & editing. **Viktor Milushev:** Writing – original draft, Investigation. **Martin Mittwollen:** Project administration, Writing – review & editing. **Timo Lehmann:** Writing – original draft, Investigation. **Felix Rauscher:** Writing – original draft, Investigation. **Georg Fischer:** Writing – original draft, Visualization, Investigation. **Paolo Pagani:** Writing – original draft, Investigation. **Yan Wang:** Writing – original draft, Investigation. **Carsten Baars:** Writing – original draft, Investigation. **Alberto Vale:** Project administration, Writing – review & editing, Investigation.



## Declaration of Competing Interest

The authors declare that they have no known competing financial interests or personal relationships that could have appeared to influence the work reported in this paper.

## Acknowledgements

The work to develop the pre-concept maintenance system design has been undertaken by many EUROfusion Research Units across Europe including:

UKAEA, RACE, UK 

IST, Instituto Superior Técnico, Portugal   ipfn  
INSTITUTO DE PLASMAS  
E FUSÃO NUCLEAR

ENEA, Brasimone Research Centre, Italy 

VTT, the Technical Research Centre of Finland 

KIT, the Karlsruhe Institute of Technology, Germany 

CEA, Alternative Energies and Atomic Energy Commission,

France 

CIEMAT, Centre for Energy, Environment and Technology Research,

Spain 

This work has been carried out within the framework of the EUROfusion Consortium and funded from the Euratom research and training programme 2014-2018 and 2019-2020 under grant agreement No. 633053. The views and opinions expressed herein do not necessarily reflect those of the European Commission.

The authors would also like to thank the Remote Maintenance System review panel involved in the Gate 1 process, and in particular the panel chair, David Maisonier, for highlighting the importance of RM, its impact on the availability factor of a fusion power plant and the need to address RM as part of the entire plant within leadership of the DEMO Central Team.

## References

- [1] EUROfusion, The demonstration power plant: DEMO. <https://www.eurofusion.org/programme/demo/> (2019) Accessed 2021-10-08.
- [2] D.J. Ward, et al., The economic viability of fusion power, *Fusion Engineering and Design* 75-79 (2005) 1221–1227.
- [3] M. Siccinio et al., Development of the plasma scenario for EU-DEMO: status and plans, this issue.
- [4] V. Curato et al., The DEMO Magnet System – Status and Future Challenges, this issue.
- [5] M.T. Porfiri et al, DEMO - Main Achievements in the Generic Site Safety Report, this issue.
- [6] J. Keep, et al., Remote handling of DEMO breeder blanket segments: Blanket transporter conceptual studies, *Fusion Engineering and Design* 124 (2017) 420–425. Volume pages <https://doi.org/10.1016/j.fusengdes.2017.02.016>.
- [7] D. Chauvin et al., Design & feasibility of Breeding blanket vertical segment-based architecture, this issue.
- [8] G. Federici et al., Plan Forward for EU DEMO, this issue.
- [9] K. Keogh, et al., Laser cutting and welding tools for use in-bore on EU-DEMO service pipes, *Fusion Engineering and Design* 136 (2018) 461–466, <https://doi.org/10.1016/j.fusengdes.2018.02.098>. VolumePart APagesISSN 0920-3796.
- [10] European Committee for Standardization, Welding (Electron and laser beam welded joints — Guidance on quality levels for imperfections - Part 1:Steel), EN ISO 13919-1 2019.
- [11] S. Kirk, et al., Laser welding of fusion relevant steels for the European DEMO, *Fusion Engineering and Design* 136 (2018) 612–616, <https://doi.org/10.1016/j.fusengdes.2018.03.039>. Part APagesISSN 0920-3796.
- [12] A. Vale, J. Dias, Path planning and space occupation for remote maintenance operations of transportation in DEMO, *Fusion Engineering and Design* Vol. 146 (2019) 325–328, <https://doi.org/10.1016/j.fusengdes.2018.12.057>. Part A.

- [13] A. Vale, FFMECA and recovery strategies for ex-vessel remote maintenance systems in DEMO, *Fusion Engineering and Design* Vol. 124 (2017) 619–622, <https://doi.org/10.1016/j.fusengdes.2017.02.101>.
- [14] F. Rauscher, et al., A digital twin concept for the development of a DEMO maintenance logistics modelling tool, *Fusion Engineering and Design* 168 (2021), 112399.
- [15] G. Federici et al, The EU DEMO staged design approach in the Pre-Concept Design Phase, this issue.