

F. Dhall, S. Mistry, I. Turner, T.R. Barrett, I. Day and R. McAdams

# High Heat Flux Engineering for the Upgraded Neutral Beam Injection Systems of MAST-U

Enquiries about copyright and reproduction should in the first instance be addressed to the Culham Publications Officer, Culham Centre for Fusion Energy (CCFE), Library, Culham Science Centre, Abingdon, Oxfordshire, OX14 3DB, UK. The United Kingdom Atomic Energy Authority is the copyright holder.

# High Heat Flux Engineering for the Upgraded Neutral Beam Injection Systems of MAST-U

F. Dhall<sup>1</sup>, S. Mistry<sup>1</sup>, I. Turner<sup>1</sup>, T.R. Barrett<sup>1</sup>, I. Day<sup>1</sup> and R. McAdams<sup>1</sup>

<sup>1</sup>*CCFE, Culham Science Centre, Oxfordshire, OX14 3DB, UK*



# High Heat Flux Engineering for the Upgraded Neutral Beam Injection Systems of MAST-U

F. Dhalla, S. Mistry, I. Turner, T. R. Barrett, I. Day and R. McAdams

CCFE, Culham Science Centre, Oxfordshire, OX14 3DB, UK.

For the initial phase of MAST-U operation the two existing neutral beam injection systems will be used, but must be substantially upgraded to fulfil expected operational requirements. The major elements are the design, manufacture and installation of a bespoke bending magnet and Residual Ion Dump (RID) system. The MAST-design full energy dump is being replaced with new actively-cooled full, half and third energy dumps, designed to receive 2.4MW of ion power deflected by an iron-cored electromagnet. The main design challenge is limited space available in the vacuum vessel, requiring ion-deflection calculations to ensure acceptable heat flux distribution on the dump panels. This paper presents engineering and physics analysis of the upgraded MAST beamlines and reports the current status of manufacture.

Keywords: MAST-U; Neutral Beam Injection; Ion Dump; High Heat Flux; Hypervapotron; Swirl Tube.

## 1. Introduction

The Mega-Ampere Spherical Tokamak (MAST) at the Culham Centre for Fusion Energy (CCFE) is undergoing a major upgrade. Facilitating physics goals to develop fusion technologies for testing reactor concepts, MAST Upgrade (MAST-U) will enable studies of effectively steady-state plasma performance, with increased pulse lengths of 5s. Longer plasma discharges will be driven initially by up to 5 MW of Neutral Beam Injection (NBI) from two beamlines using MAST design Positive Ion Neutral Injectors (PINI) capable of 2.5MW injected power [1]. The full upgrade foresees the addition of a double neutral beamline, with two more ion sources, raising total injected power to 10MW [2], which will be implemented in the next phase.

A major part of the present shutdown is to upgrade the NBI systems to increase their operational envelope to meet the MAST-U requirements. The focus of the present upgrade work has been to design a new Bend Magnet and Residual Ion Dump (RID). Design scoping to deliver an integrated layout suitable for housing within the limited space constraints inside the vacuum tank (see Fig. 1) was performed using the in-house MAGNET code enhanced numerical ion-tracing analysis software. Finally, Finite Element (FE) thermo-mechanical analyses were performed to validate the designs of the high heat flux dump elements and demonstrate compliance with the ITER in-vessel component structural design rules [3].

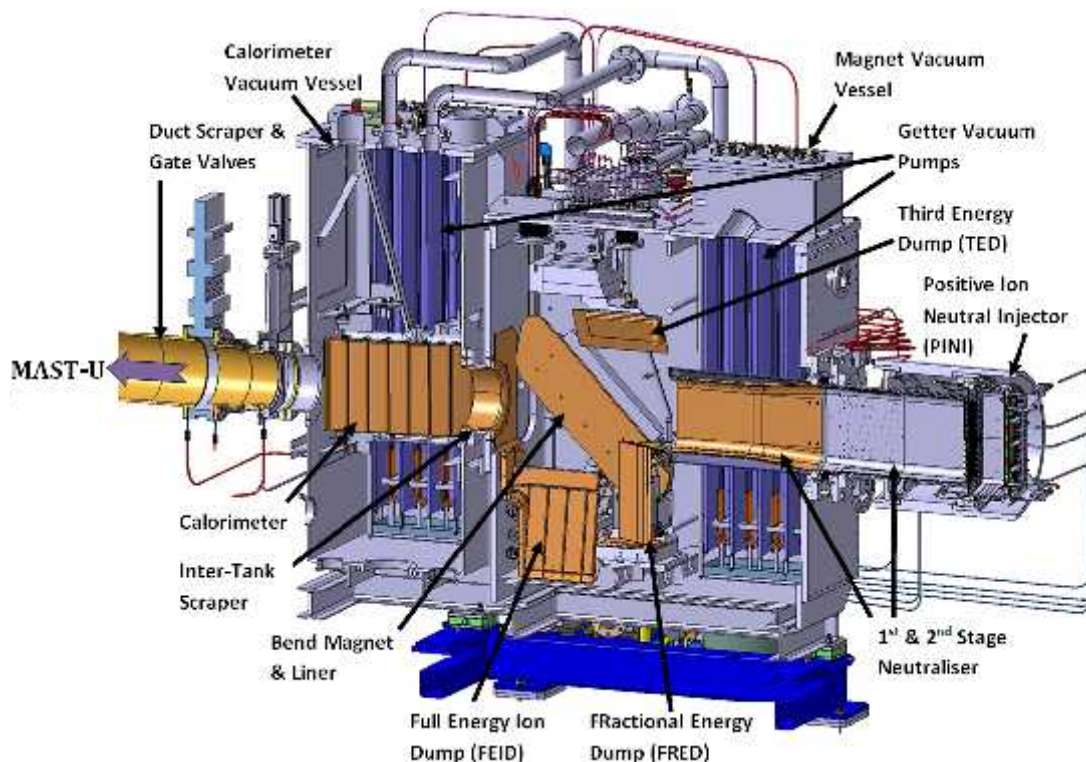

Fig. 1: New RIDs & Bend Magnet Layout in Vacuum Tanks.

## 2. RID and Bend Magnet System Design

### 2.1. Ion-Deflection Modelling

MAGNET, which is a Culham in-house code, is used as a tool to calculate the location and magnitude of the incident power density on the beamline components. As an input, this code takes a 3D magnetic field map and rectangular planes in 3D coordinates which define the component surfaces. The beam setup uses a 75kV 65A beam, with both supercusp and chequerboard PINI source configurations. The magnetic field and RID geometry design space was iteratively explored to produce a system with acceptable power footprints on the dump panels. Magnetic analyses were performed with ANSYS software [4]; coil dimensions, position and magnet material were all varied as part of the design optimisation suitable for the compact area.

Different concepts were explored, settling on a more powerful bending magnet. This new magnet will bend the residual ions significantly more than the old magnet meaning that the ions are dispersed more, separating the incoming ion beam into broadly full, half and third energy components. From the PINI source in chequerboard configuration using deuterium, the  $D^+$ ,  $D_2^+$ ,  $D_3^+$  flux ratios are 70/ 22/ 8% and density ratios are 60.9/ 27.1/ 12.0%. This allowed for three separate dumps to be used, spreading the power loading over a larger number of plates, adding significant complexity to the design, but resulting in acceptable power footprints.

The MAGNET results were also validated using the commercial OPERA code [5] (see Fig. 2). The separation of the ion fractions by the new bend magnet design can be clearly seen. The full energy ions are deflected about 85°, the half energy ions about 135° and the third energy ions turn almost 270°. The power footprints calculated in OPERA match the MAGNET results closely. OPERA was also used to show that the beam is effectively fully space-charge compensated.

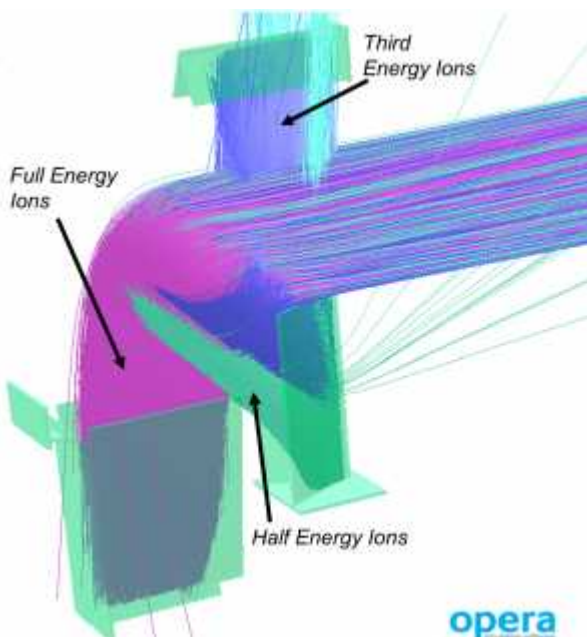

Fig. 2: OPERA modelling – Deflection of Full, Half and Third Energy Residual Ions by Bending Magnet on to the dumps.

The PINIs can be operated in either supercusp or chequerboard source configurations. The supercusp source provides the highest loading conditions on the Full Energy Ion Dump (FEID), but the chequerboard source (expected to be used most often in MAST-U) provides a higher neutral beam fraction. Consequentially the fractional residual ion power also rises; further justifying using separate cooled fractional energy ion dumps.

Molecular ion and re-ionised power loads have also been modelled. Using an input gas profile, MAGNET is able to make a step-wise calculation of the neutral beam re-ionisation and deflection of the ions. This loading accounts for an additional 115kW of power on the FEID, which also required consideration in the engineering design of the dumps.

### 2.2. Mechanical Design Overview

The upgraded RID design now constitutes three separate dumps (see Fig. 3). The FEID that intercepts the full-energy residual ion power is situated on the base of the vacuum tank, installed from the side of the tank and built off an existing port door. The FRactional Energy Dump (FRED) that intercepts the half-energy residual ion power is mounted on the base of the bend magnet and finally the Third Energy Dump (TED) which intercepts the third-energy ions is mounted from the top of the bend magnet. The magnet assembly including FRED, TED and pipework will be fixed to the lid of the tank and installed as a complete assembly.

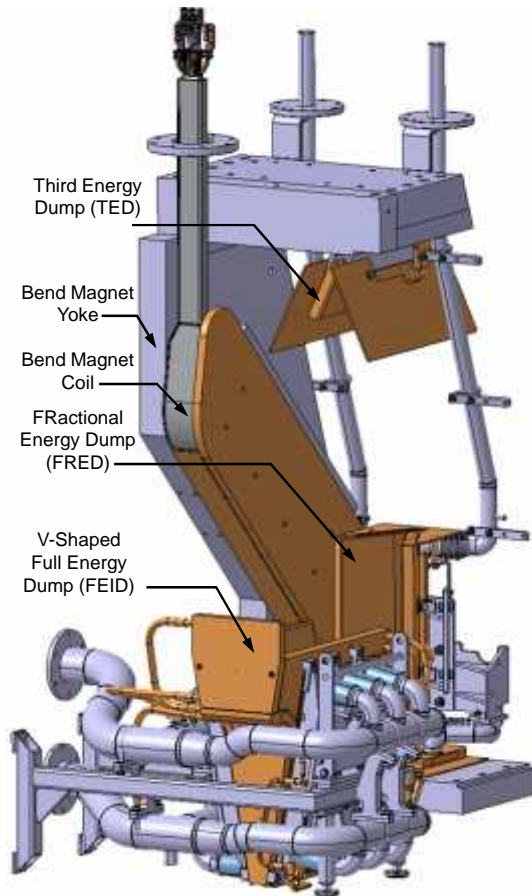

Fig. 3: Full, Half and Third Energy Residual Ion Dumps with the Bend Magnet. (The Bend Magnet is symmetric with the right-hand coil hidden for clarity).



The main design challenge has been the limited space available in the tanks. The residual ions do not travel far before hitting the dumps so are unable to diverge and disperse significantly; therefore the ion power densities on the components are high and necessitating active-cooling. The FEID is made up of six Copper Chrome Zirconium (CuCrZr) alloy Hypervapotron (HVT) beam stopping elements arranged in a 'V' [6].

The FRED consists of an arrangement of three CuCrZr alloy plates in which active-cooling is achieved through an arrangement of deep-drilled holes that form a cooling circuit. These elements have stainless steel twist tape elements (also known as swirl tube elements) within the deep-drilled holes to promote turbulent heat transfer and enhance the cooling efficiency of the component. The vertical FRED plates and the back plate of the FEID are curved to further spread out the residual ion loading.

The TED is made of three CuCrZr alloy plates with copper cooling tubes embedded and brazed into the back to provide inter-pulse cooling. The inertial thermal capacity of the plates is sufficient to cope with the 35kW of power from the third energy ions during a 5s pulse.

To match the increased cooling requirements a new water cooling system is required. Bellows in the pipework account for vibration and the deflection of the actively-cooled plates. Flow restrictors are integrated into the pipework to balance the flow rates, confirmed by component and system flow testing, ensuring the most loaded dump elements receive the design flow rate.

### 2.3. Plate Cooling Optimisation

While capturing all residual ions, the dump elements are oriented to have a shallow incidence angle spreading the power load over a larger area. Based on past design and operational experience of high-heat flux elements at CCFE, the working limit for the HVT elements is 12MW/m<sup>2</sup> [6] and 8MW/m<sup>2</sup> is a sensible structural limit for the deep-drilled panels.

The HVTs from the current RID are being re-used in a new V-shaped configuration, with CuCrZr inertial plates around the periphery. The majority of the residual ion energy is of the full energy fraction leading to a power load of 1.75MW landing on the FEID. After design development the peak power density is kept to a peak of 12MW/m<sup>2</sup> (see Fig. 4). Cooling water enters the HVTs at 2 bar and flows at up to 8m/s. The data from MAGNET has been input into an ANSYS FE model of the FEID, predicting a peak steady-state operating temperature of 370°C during a 5s pulse. For MAST-U operation the thermal limit for CuCrZr to avoid material softening during its operational lifetime is 400°C.

Packaging the FRED in a compact orientation inside the bending magnet underneath the neutral beam path has been a major challenge. To deliver the high Heat Transfer Coefficient (HTC) required inside the swirl tubes on the FRED while suppressing the onset of boiling, the plates have to be pumped at 10 bar with 8kg/s of water each. The FRED plates are connected in series avoiding excessive cooling water requirements.

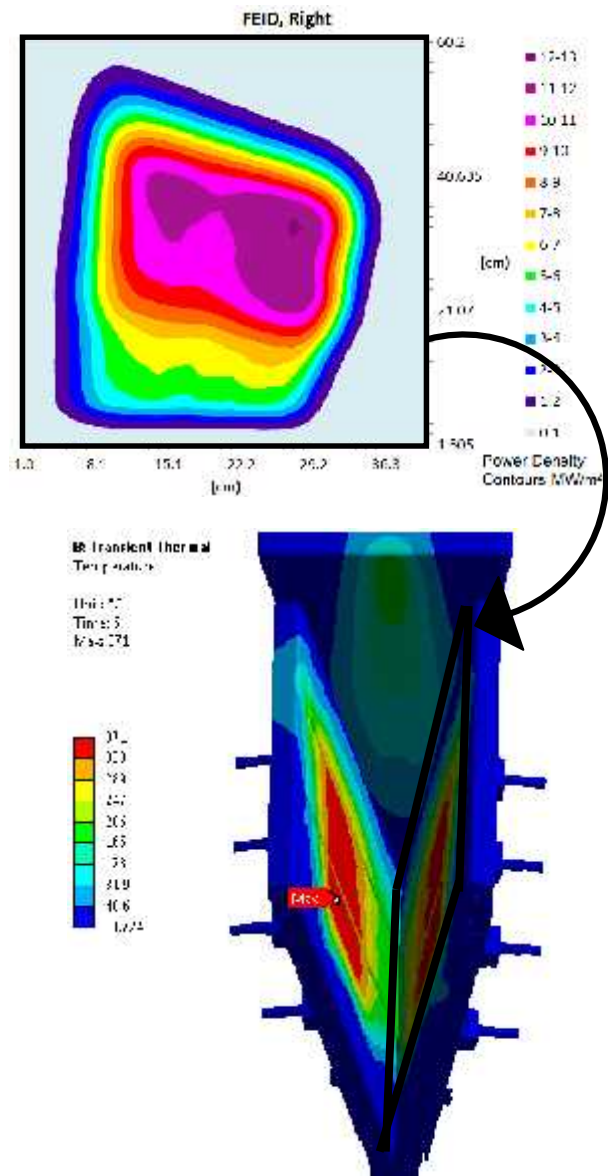

Fig. 4: MAGNET and ANSYS FE Analysis of Thermal Loading on the FEID from deflected Full Energy Residual Ions.

To accommodate the load of the half-energy ions (see Fig. 5) the design of the FRED plates required the swirl tubes to be arranged close together in the location of highest power; 5mm from the heated face with a minimum 5mm gap between each other. While avoiding high operating temperatures this minimises thermal gradients and avoiding excessive thermal stresses. After optimisation of the FRED geometry using MAGNET the loading of 260kW with a peak power density of 7MW/m<sup>2</sup> was analysed using an ANSYS FE model of the FRED, predicting a peak steady-state operating temperature of 240°C, reached 1.8s into a 5s pulse.

The forced convection model accounts for the beneficial presence of the twist tape and where nucleate boiling occurs by varying the HTC. A Critical Heat Flux (CHF) margin of 3.5 ensures that fully developed boiling will not occur and the high HTC can be sustained in all operating conditions.

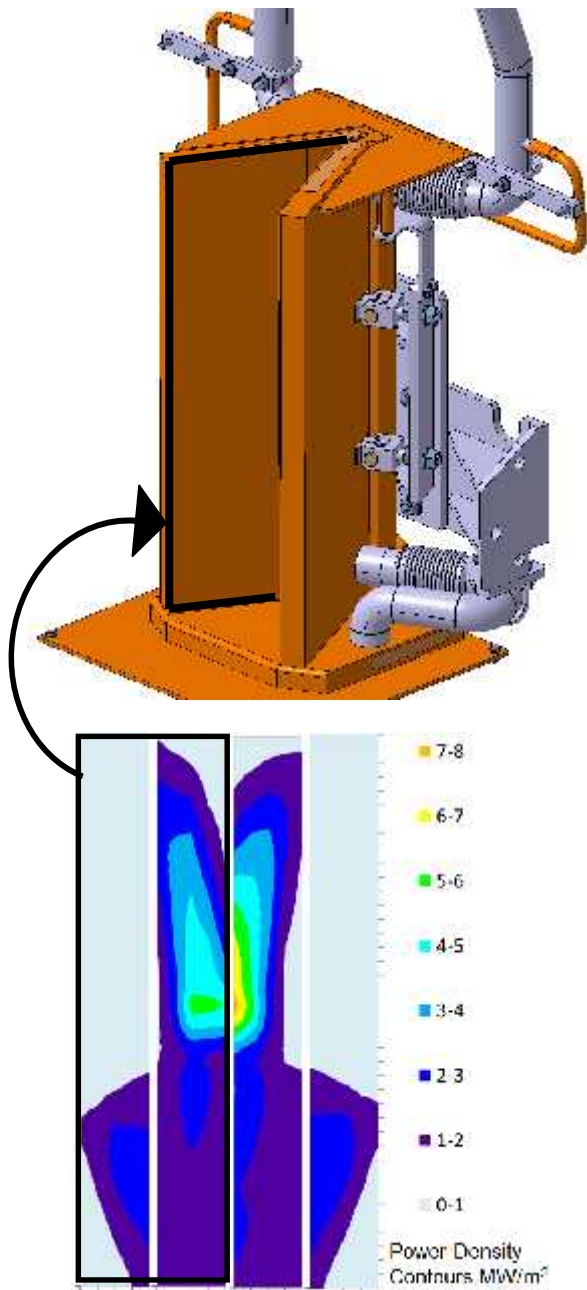

Fig. 5: MAGNET Optimisation – Minimising Power Loading on FRED, varying position and geometry.

The new ion dumps have been analysed against the ITER SDC-IC code [3]. Although the pressure-induced primary stresses on these components are small, the thermal loading is high and results in high secondary stresses. While the yield stress of the CuCrZr material is initially expected to be exceeded, material shakedown was proven through a linear elastic-plastic analysis of the FE model. Fig. 6 illustrates the location of the peak von Mises stress of 200MPa at which a total strain of 0.16% was found. At the location of peak stress, elastic shakedown was observed to occur and as the extent of plasticity only reaches 2mm through the surface of the model gross deformation is not expected. Fatigue analysis on the basis of the strain range calculated through this method predicted 200,000 operating cycles, which is well over the MAST-U requirements of 100,000 cycles for the Neutral Beam System.

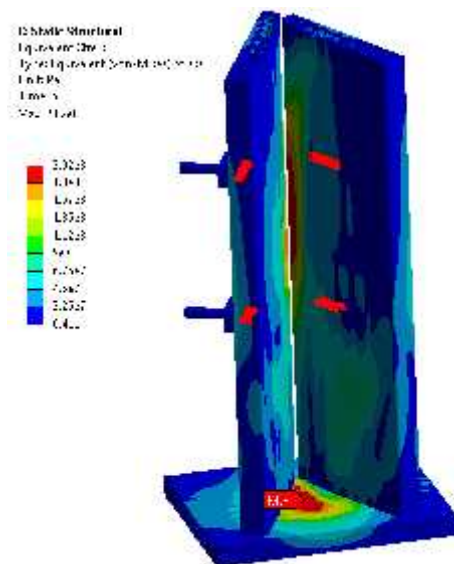

Fig. 6: ANSYS FE Linear Elastic-Plastic Analysis.

### 3. Summary and Status of Procurement

The new RID and Bend Magnet System for the upgraded MAST-U NBI systems have been designed to operate using a chequerboard configuration PINI in tight space constraints for the 5s MAST-U pulse requirements. The Bend Magnet Coils, Yoke and CuCrZr water-cooled plates are in the procurement phase and being manufactured. High purity CuCrZr plates with a Zr content of < 0.07% have been specially forged for material strength, and good weld ability. From JET only 0.07% Zr goes into solution in large scale production; higher levels of Zr gives less malleability since the Zr not driven into solution forms  $\text{Cu}_3\text{Zr}$  intermetallic. Electron beam welding and vacuum brazing for the CuCrZr plates are being carried out by European specialists, whilst the Bend Magnet coils and yoke are being wound and built at a British electromagnet specialist. The supporting framework and pipework is being assembled and welded for installation in 2015.

### Acknowledgements

This work was funded by the RCUK Energy Programme [under grant EP/I501045]. To obtain further information on the data and models underlying this paper please contact PublicationsManager@ccfe.ac.uk. The views and opinions expressed herein do not necessarily reflect those of the European Commission.

### References

- [1] T. Barrett, et al, "Engineering design of the double neutral beam injection system for MAST Upgrade." Fusion Eng. Des. Vol. 86, (2011), p789–792
- [2] S.J. Gee, et al, "MAST neutral beam long pulse upgrade." Fusion Eng. Des. Vol. 74, (2005), p403-407
- [3] ITER Structural Design Criteria for in-vessel components. ITER IDM Reference 222RHC v3.0
- [4] ANSYS Workbench Framework Version 15.0
- [5] Cobham OPERA - <http://charged-particle-devices.com/>
- [6] J. Milnes, et al, "HyperVapotron design for the long pulse upgrades on MAST NBI." 20th IEE/NPSS Symposium on Fusion Engineering, (2003), pp. 478–481