

R. McAdams, A. Sparkes, A. Ash, I. Day, D. King, M. Kovari, A. Shepherd,
I. Turner, J. Zacks, D. Ćirić and JET EFDA Contributors

Preparation for the next JET Tritium Campaign: Performance of the EP2 PINIs with Grid Gas Delivery

Enquiries about copyright and reproduction should in the first instance be addressed to the Culham Publications Officer, Culham Centre for Fusion Energy (CCFE), Library, Culham Science Centre, Abingdon, Oxfordshire, OX14 3DB, UK. The United Kingdom Atomic Energy Authority is the copyright holder.

Preparation for the next JET Tritium Campaign: Performance of the EP2 PINIs with Grid Gas Delivery

R. McAdams¹, A. Sparkes¹, A. Ash¹, I. Day¹, D. King¹, M. Kovari¹, A. Shepherd¹,
I. Turner¹, J. Zacks¹, D. Ćirić¹ and JET EFDA Contributors^{*}

¹*CCFE, Culham Science Centre, Abingdon, Oxon OX14 3DB, UK*

^{*}*See the Appendix of F. Romanelli et al., Proceedings of the 24th IAEA Fusion Energy Conference 2012, San Diego, US*

Preparation for the next JET tritium campaign: performance of the EP2 PINIs with grid gas delivery

R McAdams, A Sparkes, A Ash, I Day, D King, M Kovari, A Shepherd, I Turner, J Zacks, D Ćirić and JET EFDA Contributors*

JET-EFDA, Culham Science Centre, Abingdon, OX14 3DB, UK

In normal operation the JET Neutral Beam Injectors have the operating gas supplied to the ion source and the neutraliser. For tritium operation the gas is supplied to both the ion source and neutraliser at a point close to the earth grid (“grid gas”) due to the difficulty in producing a gas line with a secondary containment and a ceramic break for high voltage standoff. In preparation for the next JET tritium campaign the JET EP2 PINIs have been characterised with grid gas flow. This paper reports measurements of arc efficiency, species and divergence in both normal and grid gas operation with hydrogen and deuterium. The data is used to predict the performance in tritium operation.

Keywords: JET, Neutral Beam Injection, Tritium

1. Introduction

The Joint European Torus (JET) is equipped with two Neutral Injector Boxes (NIBs) each consisting of eight injectors or PINIs (Positive Ion Neutral Injectors) [1]. These injectors are presently the EP2 type [2], each operating at up to 125kV, 65A of deuterium positive ions resulting in a maximum deuterium neutral beam power of 2.13MW injected into JET i.e. a total of ~34MW. Preparations are currently underway for the next tritium campaign on JET which is scheduled for 2017. This campaign will include phases where both injection boxes operate with tritium and then one injection box operates in tritium and the other in deuterium. Based on present performance, the predicted performance in tritium operation is 2.2MW of neutral beam power per injector for an extracted current of 45A at 118kV [2] giving a total neutral beam power in tritium of ~35MW.

In normal deuterium operation the ion source operating pressure and the neutraliser gas target are established by supplying gas directly to the ion source which is at high voltage and also to a point approximately half way along the neutraliser. There is an insulating break in the ion source gas line made of glass located in an SF₆ tower. For tritium operation such a system is unsuitable due to the engineering difficulties of designing and manufacturing a long ceramic break in the gas line with secondary containment in case of a tritium leak. To overcome this problem a special gas delivery system is used where all the gas for both the source and neutralizer is fed to the injector at the earth grid. This is known as the Tritium/Deuterium Gas Introduction System (TDGIS) or the “grid gas” delivery system [3,4]. The system delivers deuterium gas as well as tritium.

This paper describes testing of the EP2 injectors with grid gas operation and compares their performance with normal gas operation. This is necessary since (as shown in the next section) at the same total gas flow the source pressure is less in grid gas operation than in normal gas

operation. Increasing the grid gas flow rate could lead to high voltage standoff issues. Furthermore the reduced source pressure may lead to reduced arc efficiency. Thus it is important to ensure that the required performance can be achieved in grid gas operation.

2. Grid gas operation

A simple conductance model can be used to understand the pressures at the earth grid for both normal gas operation and grid gas operation. Figure 1a shows a schematic of normal gas operation and Figure 1b shows a schematic of grid gas operation

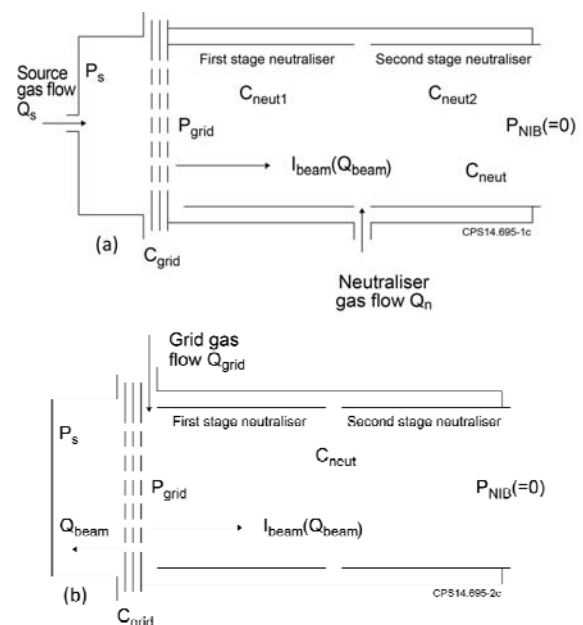

Fig.1. Schematic of the gas flows and pressures in (a) normal gas operation (b) grid gas operation

In normal gas operation the source and neutraliser gas flows are Q_s and Q_n respectively. The conductance of the first and second stage neutralisers are C_{neut1} and

Corresponding author's email: roy.mcadams@ccfe.ac.uk

*See the Appendix of F. Romanelli et al., Proceedings of the 24th IAEA Fusion Energy Conference 2012, San Diego, US

C_{neut2} respectively; with a total neutraliser conductance of C_{neut} . The accelerator grids have a conductance C_{grid} . In grid gas operation the gas flow rate is Q_{grid} . The ion source pressure is P_s and the pressure at the earth grid is P_{grid} . The extracted beam has an equivalent gas flow of Q_{beam} . The NIB pressure is assumed to be zero.

This simple picture allows the pressure at the earth grid to be calculated in normal, $(P_{grid})_{Norm}$, and grid gas, $(P_{grid})_{Grid\ gas}$, operations. A comparison is made where the grid gas flow is equal to the total of the source and neutraliser flow rates, $Q_{grid} = Q_s + Q_n$ giving

$$\frac{(P_{grid})_{Norm}}{(P_{grid})_{Grid\ gas}} = \frac{\frac{Q_s}{C_{neut}} + \frac{Q_n}{C_{neut2}}}{\frac{Q_s}{C_{neut}} + \frac{Q_n}{C_{neut}}} < 1 \quad \text{#####1}\#$$

The effect of the gas flow of the beam has been neglected and so these represent filling pressures. The inequality arises since $Q_n/C_{neut} > Q_n/C_{neut2}$. Thus at the same total gas flow rate the pressure at the earth grid will be higher for grid gas operation. The source filling pressure in grid gas operation, $(P_s)_{Grid} = (P_{grid})_{Grid}$. The filling pressure in normal gas operation is $(P_s)_{Norm} = (P_{grid})_{Norm} + Q_s/C_{grid}$. Using gas flow rates of $Q_s = 12$ mbar l/s (1.2 Pa m³/s) and $Q_n = 20$ mbar l/s (2 Pa m³/s) together with estimates of $C_{grid} = 1.7$ m³/s, $C_{neut} = 3.8$ m³/s and $C_{neut2} = 10.6$ m³/s the source pressure and earth grid pressure in normal gas operation are $\sim 13 \times 10^{-3}$ mbar (1.3 Pa) and 6.6×10^{-3} mbar (0.66 Pa) respectively. In grid gas operation the source pressure and earth grid pressure are $\sim 8.5 \times 10^{-3}$ mbar (0.85 Pa). Thus in grid gas operation the source filling pressure is less and the pressure at the earth grid is higher than in normal gas operation. This conclusion is supported by Jones et al. [3] who found an empirical fit to the measured pressure at the earth grid for normal and grid gas operation. Specifically, for the type of PINIs used (non EP2)

$$P_{grid} = M^{\frac{1}{2}} [0.348 (Q - Q_{beam})^{0.96} + 0.126 Q_n^{0.94} - 0.0336 (Q - Q_{beam})^{0.96} Q_n^{0.94}] \quad (2)$$

M is the isotopic mass and P_{grid} is measured in Pa and Q , Q_n and Q_{beam} are given in Pa m³ s⁻¹. In normal gas operation $Q = Q_s$ and in grid gas $Q = Q_{grid}$ and $Q_n = 0$.

The increased pressure at the earth grid and lower operating pressure in the ion source in grid gas mode means that there is potential for voltage standoff and arc efficiency issues. In grid gas operation there is a flow of gas into the source to balance the reduction in source pressure due to beam extraction and $P_s = P_{grid} - Q_{beam}/C_{grid}$. For the EP2 PINIs 60A represents $Q_{beam} \sim 10$ mbar l/s (1 Pa m³/s) and so the pressure drop to the source from the earth grid is $\sim 5.9 \times 10^{-3}$ mbar (0.59 Pa). For a 45A tritium beam $Q_{beam} \sim 7.5$ mbar l/s (0.75 Pa m³/s) and the grid conductance is 1.39 m³/s giving a pressure drop of $\sim 5.4 \times 10^{-3}$ mbar (0.54 Pa). Thus at the same pressure at the grid the source pressure will be higher in tritium.

In Figure 2 the physical implementation of grid gas delivery in the injector is shown. A seal is introduced between the first stage neutralizer and the earth grid box

holder and the single ground potential gas feed is located close to the earth grid (G4 in the case shown).

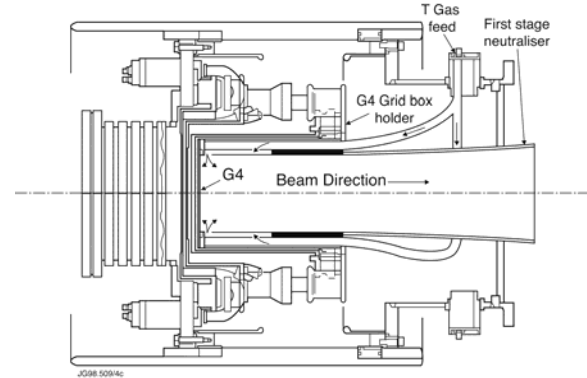

Fig.2. Horizontal section of a JET PINI showing the grid gas introduction at the earth grid (G4 in this case)

3. The JET Neutral Beam Test Bed

A number of PINIs have been compared to date in normal gas and grid gas operations. The measurements have been made at the JET Neutral Beam Test Bed (NBTB) [1] as shown in Figure 3. Together with electrical measurements of discharge and beam parameters, the Test Bed is equipped with various diagnostics. Inertial (thermocouple based) and water calorimetry at the beam dump allow beam profiles to be measured at a distance of 10-12m. Carbon Fibre Composite (CFC) tiles are used to give two dimensional profiles and Doppler spectroscopy is used for ion species determination.

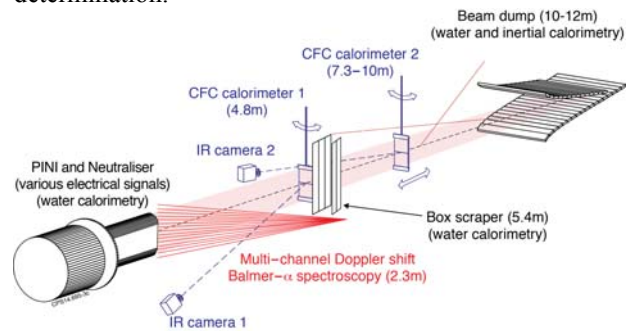

Fig.3 (Colour online). The JET Neutral Beam Test Bed

4. Comparison between normal and grid gas operation

In Figure 4 the extracted positive ion current for operation in normal gas with both hydrogen and deuterium is shown for PINI 5E2T as the arc current is changed. Data is presented for different source gas flow rates of 10, 12 and 14 mbar l/s (1, 1.2 and 1.4 Pa m³/s). The neutraliser gas flow rate in all cases is 20 mbar l/s (2 Pa m³/s). These gas flow rates are the usual operating values for the PINIs. The data is linear as the arc current changes and the arc efficiency is very similar for both hydrogen and deuterium with no dependence on the source gas flow rate. The maximum positive ion current for deuterium was 60A at 120kV and for hydrogen was 57A at 94kV. This is a reflection of the Child-Langmuir scaling $I \sqrt{M_{eff}} / V^{3/2} = \text{constant}$ where I is the current, M_{eff} the effective mass of the beam particles taking into

account the different species (H^+/D^+ , H_2^+/D_2^+ , H_3^+/D_3^+ etc. and V is the extraction voltage. The current is limited to 60A by the NBTB high voltage power supply.

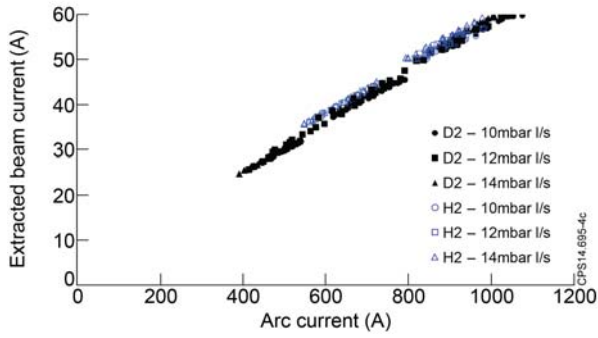

Fig.4 (Colour online). Extracted positive ion current for PINI 5E2T in hydrogen and deuterium at different source gas flow rates with a neutraliser gas flow rate of 20 mbar l/s

The extracted positive ion current for grid gas operation is shown in Figure 5 for both hydrogen and deuterium at different grid gas flow rates. In hydrogen a current of 55A is achieved at 94kV beam voltage for a grid gas flow rate of 34 mbar l/s (3.4 Pa m³/s). At a grid gas flow rate of 29 mbar l/s (2.9 Pa m³/s) in deuterium a current of 59A is achieved with a beam voltage of 114kV.

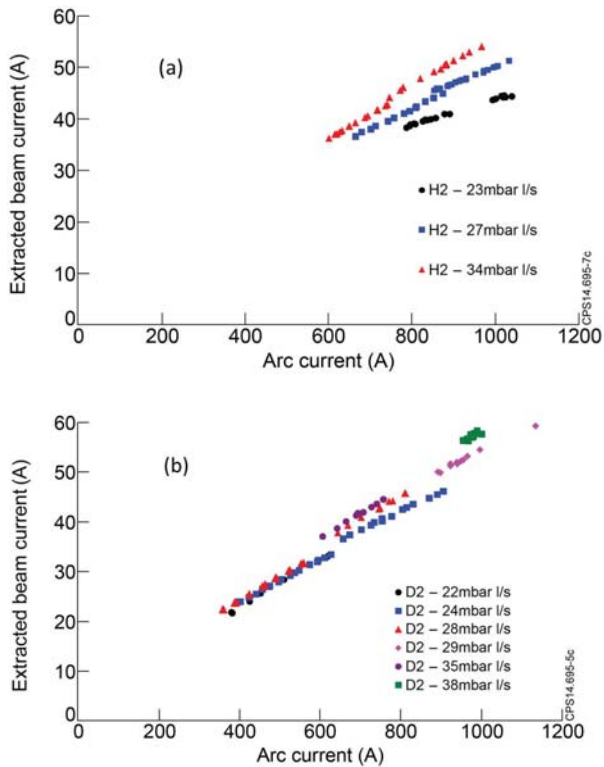

Fig.5 (Colour online). Extracted positive ion current for PINI 5E2T in (a) hydrogen and (b) deuterium at different grid gas flow rates

The data for hydrogen shows a marked dependence on the grid gas flow rate at high arc currents. At low grid gas flow rate the arc efficiency is almost constant at high arc current (gas starvation). This dependence of grid gas flow rate is also observed in the deuterium data but to a lesser degree. At low arc currents the data appears to be

independent of gas flow rate. This dependence of the arc efficiency on gas flow rate at high arc current can be understood qualitatively in terms of a relatively simple model of the discharge [5]. This model can be written as

$$\frac{I_e}{I_+} = \frac{S_{in}}{S_{ion}} + \frac{1}{N\tau S_{ion}} \quad (3)$$

where I_e is the emitted electron current from the ion source filaments, I_+ is the positive ion current produced in the source and N is the ion source gas density. The parameters S_{in} and S_{ion} are the rate coefficients for inelastic and ionisation collisions of the electrons in the source plasma, τ is the confinement time of the primary electrons emitted by the filaments. I_e is related to the arc current and I_+ to the extracted positive ion current. This model can be used to qualitatively explain the dependence on source pressure. In normal gas operation for the flow rates used the arc efficiency is independent of the gas flow rate then $S_{in}/S_{ion} \gg 1/N\tau S_{ion}$. This must also be the case in grid gas flow mode at low arc currents. At high arc currents the arc efficiency is dependent on grid gas flow rate and hence on the pressure in the source i.e. the second term on the right hand side of equation 3 dominates. The conductances are higher for hydrogen than for deuterium and the pressures will be lower at the same grid gas flow rate leading to a greater dependence on source pressure for hydrogen operation.

The arc efficiency for three PINIs in both normal operation and grid gas operation for both hydrogen and deuterium are shown in Figure 6. The data shown is for normal gas operation with the source gas flow > 12 mbar l/s (1.2 Pa m³/s) and a neutraliser gas flow rate of 20 mbar l/s (2 Pa m³/s) and with grid gas flow rates > 29 mbar l/s (2.9 Pa m³/s). Included in the data also is a case of hydrogen operation where some of the neutralizer gas is replaced by neon. This increases the effective mass of the beam and so for a given voltage the current extracted is lower. This allows operation of the PINI at a higher voltage in hydrogen before reaching the 60A power supply limit. It is clear that, even with some neon in the source that provided the source pressure is high enough the arc efficiency is the same for hydrogen and deuterium in both normal and grid gas operation.

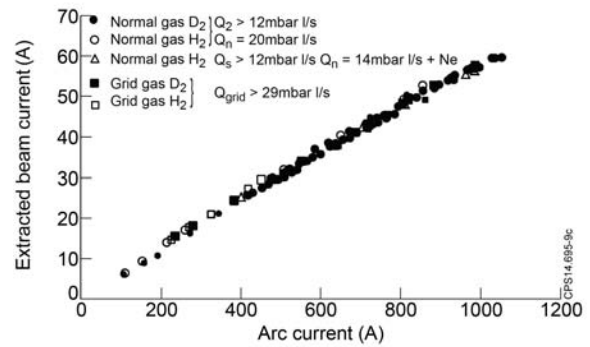

Fig.6 Extracted positive ion current for three PINIs in both normal and grid gas operation for various source gas, Q_s , neutraliser gas, Q_n and grid gas Q_{grid} flow rates.

Species (D^+ , D_2^+ , D_3^+) flux fractions determined from Doppler spectroscopy are shown in Figure 7 for PINIs

5E2T and 15E2T for normal and grid gas flows in deuterium operation. The D^+ fraction is independent of the total gas flow rate in both modes of operation. At the lowest grid gas flows the D_2^+ fraction is higher and the D_3^+ fraction is lower than in normal gas operation. The lower pressure in the source in grid gas results in a different species mix compared to normal gas operation. As the grid gas flow rate increases the D_2^+ fraction decreases and the D_3^+ fraction increases toward the normal gas mode values as the source pressure increases.

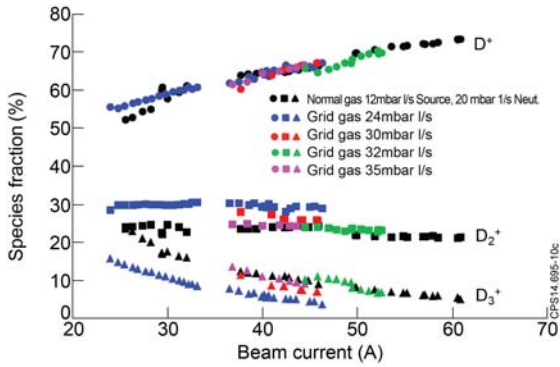

Fig.7 (Colour online). Species flux fractions in deuterium normal gas and grid gas operation

In Figure 8 for normal and grid gas modes in deuterium the $1/e$ half width of the beam at a distance of 10m is plotted against the beam perveance $I/V^{3/2}$ for PINI 5E2T. The minimum beam divergence is approximately constant.

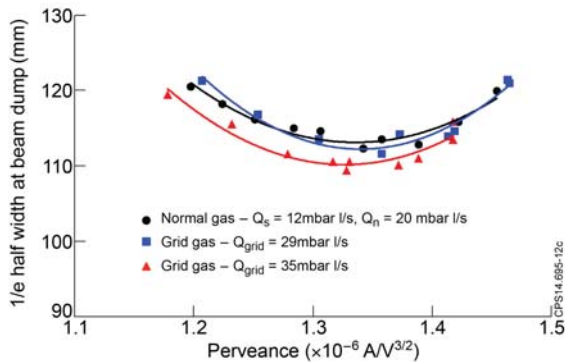

Fig.8 (Colour online). Perveance curves for deuterium operation in normal and grid gas modes

Figure 9 shows a plot of the perveance at minimum divergence (optimum perveance) for hydrogen and deuterium in normal and grid gas modes of operation. The measured perveance has been scaled by the factor $\sqrt{M_{\text{eff}}}$ where $M_{\text{eff}} = M(f^+ + \sqrt{2}f_2^+ + \sqrt{3}f_3^+)$ and f is the flux fraction from species measurements and M is the proton or deuteron mass in amu. This scaled value of optimum perveance is constant in accordance with the Child-Langmuir Law with a value of $\sim 2 \times 10^{-6} (\text{A}/\text{V}^{3/2} \text{amu}^{1/2})$.

5. Scaling to tritium operation

Tritium operation is not possible on the Neutral Beam Test Bed and so it is important to understand what performance can be expected in tritium operation on JET. The arc efficiency in deuterium is very similar to that in hydrogen in normal gas operation and also in grid

gas operation provided the flow rates are sufficiently high. It is then expected that the arc efficiency with tritium will be the same. A grid gas flow rate of greater than approximately 30 mbar l/s (3 Pa m³/s) is required in deuterium operation to achieve almost 60A. The same source and other system pressures, based on the scaling of conductance with mass, will be achieved at a tritium grid gas flow rate of greater than approximately 25 mbar l/s (2.5 Pa m³/s).

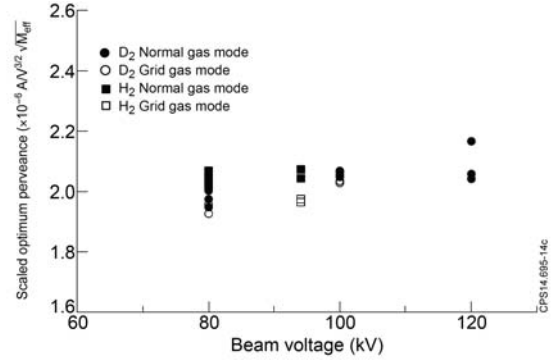

Fig.9. Optimum perveance for hydrogen and deuterium operation in normal and grid gas modes

From the scaling of the optimum perveance we have that $\sqrt{M_{\text{eff}}} \times I/V^{3/2} \sim 2 \times 10^{-6}$. From species measurements the value of M_{eff} in tritium operation are estimated to be ~ 3.6 by linear extrapolation. Hence in tritium operation at 118kV the estimated current at optimum perveance is 42.7A which is in agreement with the previous prediction of 45A [2]. The operating voltage could be increased or the injector operated at a higher than optimum perveance to increase the current.

6. Future work

On the Test Bed further characterisation in grid gas is required particularly at high power to obtain species data and support scaling to tritium. In addition, in the forthcoming campaign prior to the tritium campaign PINI operation in grid gas will be tested with deuterium on JET itself. This will include neutralisation measurements which are not possible on the NBTB.

Acknowledgements

The authors would like to thank Dr T Jones for valuable discussions and insights. This work was supported by EURATOM and carried out within the framework of the European Fusion Development Agreement. The views and opinions expressed herein do not necessarily reflect those of the European Commission.

References

- [1] G. Duesing, H. Altman, H. Falter, A. Goede, R. Hange, R. Hemsworth, et al., *Fusion Sci. Technol.* **11** (1987) 163-202.
- [2] D. Ćirić et al., *Fusion Eng. Des.* **86** (2011) 509-512
- [3] T. T. C. Jones et al., *Fusion Eng. Design* **47** (1999) 205-231
- [4] E. Surrey et al., *Fusion Sci. Technol.* **48** (2005) 280-285
- [5] A. Goede and T. Green, *Phys. Fluids* **25** (1982) 1797-1810