

Design of the ITER ICRF Antenna

D. Hancock, M. Nightingale, R. Bamber, N. Dalton, F. Durodie et al.

Citation: *AIP Conf. Proc.* **1406**, 57 (2011); doi: 10.1063/1.3664928

View online: <http://dx.doi.org/10.1063/1.3664928>

View Table of Contents: <http://proceedings.aip.org/dbt/dbt.jsp?KEY=APCPCS&Volume=1406&Issue=1>

Published by the [American Institute of Physics](#).

Related Articles

The dispersion relation and excitation of transverse magnetic mode electromagnetic waves in rippled-wall waveguide with a plasma rod and an annular dielectric

Phys. Plasmas **19**, 013109 (2012)

Variable dual-frequency electrostatic wave launcher for plasma applications

Rev. Sci. Instrum. **82**, 123501 (2011)

Properties of a capillary discharge-produced argon plasma waveguide for shorter wavelength source application

Rev. Sci. Instrum. **82**, 103509 (2011)

Waves in a bounded quantum plasma with electron exchange-correlation effects

Phys. Plasmas **18**, 102108 (2011)

Observations of Langmuir ponderomotive effects using the Solar TERrestrial RELations Observatory spacecraft as a density probe

Phys. Plasmas **18**, 082308 (2011)

Additional information on AIP Conf. Proc.

Journal Homepage: <http://proceedings.aip.org/>

Journal Information: http://proceedings.aip.org/about/about_the_proceedings

Top downloads: http://proceedings.aip.org/dbt/most_downloaded.jsp?KEY=APCPCS

Information for Authors: http://proceedings.aip.org/authors/information_for_authors

ADVERTISEMENT

**AIP Advances**

Submit Now

**Explore AIP's new
open-access journal**

- **Article-level metrics
now available**
- **Join the conversation!
Rate & comment on articles**

Design of the ITER ICRF Antenna

D. Hancock^a, M. Nightingale^a, R. Bamber^a, N. Dalton^a, F. Durodie^b,
M. Firdaouss^c, J. Lister^a, M. Porton^a, M. Shannon^a, D. Wilson^a, K.
Winkler^d, E. Wooldridge^a and the CYCLE Team^{a,b,c,d,e}

^a EURATOM/CCFE Fusion Association, Culham Science Centre, Abingdon, OX14 5ER, UK

^b ERM/KMS, Association EURATOM-Belgian State, Brussels, Belgium

^c CEA, IRFM, F-1308 Saint-Paul-lez Durance, France

^d Max-Planck Institut für Plasmaphysik, EURATOM-Assoziation, Garching, Germany

^e Politecnico di Torino, Dipartimento di Elettronica, Torino, Italy

Abstract. The CYCLE consortium has been designing the ITER ICRF antenna since March 2010, supported by an F4E grant. Following a brief introduction to the consortium, this paper: describes the present status and layout of the design; highlights the key mechanical engineering features; shows the expected impact of cooling and radiation issues on the design and outlines the need for future R&D to support the design process. A key design requirement is the need for the mechanical design and analysis to be consistent with all requirements following from the RF physics and antenna layout optimisation. As such, this paper complements that of Durodie et al [1].

Keywords: Fusion, Ion-Cyclotron, Heating, RF, ICRF, ITER, CCFE, F4E, Engineering

PACS: 28.52.Cx.

THE CYCLE CONSORTIUM AND F4E GRANT 026

The CYCLE Consortium, which came into force in 2008, consists of five European associations with ICRH expertise (CEA, CCFE, ERM, IPP, and Torino) who have agreed to collaborate on future large ICRH projects. Under F4E-2009-GRT-026, running from 1st March 2010 to February 2012, CYCLE aims to provide 3D CATIA models of the ICRF antenna and key tooling, with associated RF, thermo-mechanical and neutronic calculations, as well as undertaking quarter-scale RF mock-up studies.

PRESENT STATUS AND LAYOUT OF THE ANTENNA DESIGN

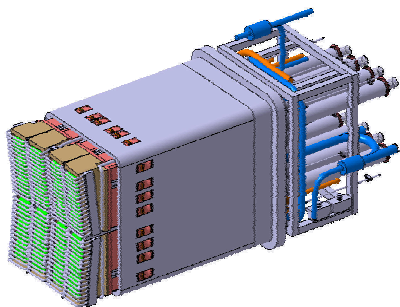

FIGURE 1. Overview of the ITER ICRF antenna showing the RF modules in the port plug body

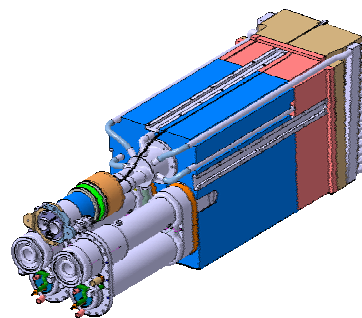

FIGURE 2. One of four RF modules with associated RVTLS

Faraday Screen

The Faraday screen provides shielding for the radiating straps and suppression of unwanted RF field characteristics. Designs currently being analysed by CEA consist of CuCrZr and Stainless Steel Structure with a Beryllium facing. HIPing¹ remains the preferred assembly method.

Straps, Four-Port-Junctions and Housing

Each of the eight transmission lines feeds three short radiating straps, fed via a slightly squared, D-Shaped, four-port junction. The straps consist of Stainless Steel pipes clad in Copper facing. The four-port-junctions are constructed from a series of drilled and welded sections. The surrounding structures are likely to be conventionally welded steel structure with copper plated RF surfaces, though HIPing remains a possibility for parts of the strap housings. The curved sections will be pressings.

Shimming, Service Shaft System, and Diagnostics Integration

Each of the four RF modules can be shimmed a total of 50mm, using pairs of off-the-shelf hydraulic jacks. The first 20mm of movement will be used on installation to deploy grounding contacts. The remaining 30mm will be available between pulses during plasma operation to optimise the distance between the plasma and the straps, in order to balance RF coupling and thermal performance. This system also acts as the service shaft for the forward components in the module, containing feed and return water pipes and providing a feed-through route for diagnostics and reflectometry. Vacuum and Tritium containment is provided by a fully welded, monitored, and replaceable double bellows arrangement.

Shielding

In order to meet the radiation and activation requirements, shielding blocks will be included at the rear of each of the RF modules. The optimal Steel:Water ratio for attenuation will be achieved via conventional deep drilling and welding methods. Radial water channels will be offset to reduce neutron streaming.

¹ Hot Isostatic Pressing

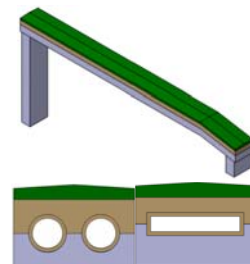

FIGURE 3. overview of one screen bar with two possible arrangements of cooling channels, showing layers of Be, CuCrZr, and Stainless Steel

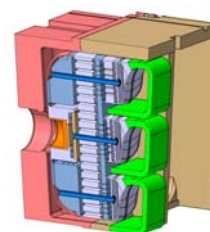

FIGURE 4. Cutaway view of one triplet of straps, four-port-junction and housing.

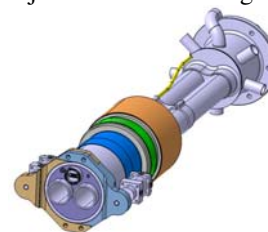

FIGURE 5. View of one shimming and service shaft showing feed and return pipes, double hydraulic jacks, double bellows arrangement, and exterior of forward cooling manifold.

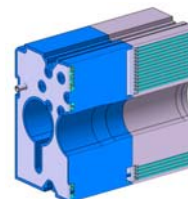

FIGURE 6. Section through a shielding module showing one set of cooling channels.

Removable Vacuum Transmission Lines and RF Vacuum Windows

Eight pairs of ceramic RF vacuum windows provide primary containment for the transmission lines. These have been developed from a technique successfully used on the JET ILA. Static fatigue and radiation considerations dictate the need for the windows to be replaced during the life of the antenna, and so they will be mounted on removable vacuum transmission lines (RVTLs). A service stub is also included which allows water to be fed to the transmission line core components. To allow the service stub to be the correct RF length, the inner conductor is “folded” concentrically in on itself, and is assembled via bore welding techniques.



FIGURE 7. section view of one RVTL showing service stub arrangement.

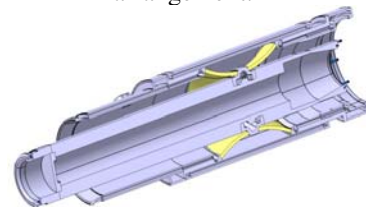

FIGURE 8. Section view of one window, showing double shaped ceramic cones

Port Plug and Grounding System

In order to mitigate parasitic resonances in the nominal 20mm gap between the port and plug, the antenna must be grounded electrically to the ITER vacuum vessel. Modelling has shown that the arrangement shown in Figure 9: a radial array of galvanic contacts ~1m recessed from the plasma edge, is sufficient. Preliminary designs for compliant mechanical actuators have been developed which use the relative movement between the port plug and the underlying module during an initial 20mm shim to deploy once the antenna has been installed in the port.

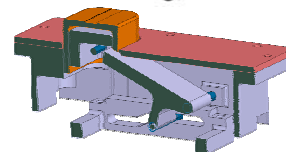
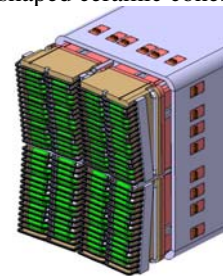

FIGURE 9. Overview of grounding contact locations and cutaway of an actuator concept

Rear Bulkhead Services Marshalling and Port Cell Structures

Connections to the antenna include: transmission lines, cooling water, service vacuum, monitored interspaces, thermocouple and RF diagnostics, reflectometry waveguides, and hydraulic lines. With many of these systems needing to penetrate the rear bulkhead, space allocation here and in the port-cell is one of the most challenging aspects of the antenna design. In addition, all of these connections, including all-welded water pipe-work are currently intended to be broken and re-made via remote handling operations during ITER’s Tritium phase.

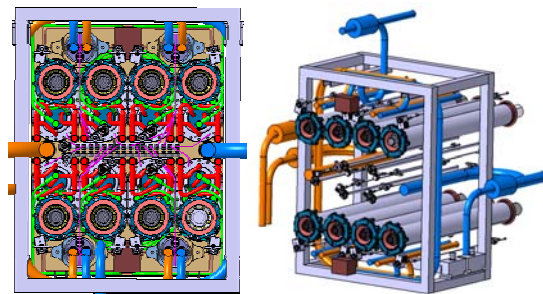

FIGURE 10. Overview of some of the rear bulkhead services, showing the competition for real-estate.

COOLING AND RADIATION ISSUES

The ITER ICRF Antenna will be subject to RF heating loads in addition to the plasma radiation, volumetric neutron heating, and incident particle flux common to all equatorial port plugs. Following analysis of the overall thermal load, the water supply has been increased to two 2.5" diameter feed pipes. Neutronic assessment of the port and antenna arrangement has shown that the largest contribution to the overall activation as well as operational dose rate in the port cell is due to streaming in the 20mm gap between port and plug.

THE NEED FOR RESEARCH & DEVELOPMENT

The behaviour of the ceramics used in the RF windows, and in many other locations on ITER, under the 14MeV neutron flux and temperatures expected during operation is poorly understood. In particular, the role of static fatigue and electrical degradation must be investigated thoroughly as part of a dedicated R&D programme before commitments are made to the design. While the fabrication techniques currently included in the design all fall within those recommended by ITER, a number of welding, plating and HIPing processes are untested for directly comparable applications and must be independently proven prior to use. A number of locations in the ICRF antenna have requirements for compliant and occasionally sliding RF gaskets. Multicontact™ provide a range of products under the Multilam™ name which have been used in fusion applications elsewhere, and present the currently preferred solution, but the specific conditions in ITER fall perilously close to or outside of the recommended operational envelopes for these, and so a further R&D programme is envisaged which will qualify or disqualify them in this case.

CONCLUSIONS

The key features of the CYCLE ITER ICRF antenna design have been presented as well as comments on radiation and cooling issues. The need for a dedicated R&D programme in the very near future has been explained. Key changes in the antenna design since 2009 [2] include: choice of assembly techniques more in line with IO preferences, inclusion of a new shimming and service shaft system, increase in available cooling water, and significant work to develop a layout for services in the port cell.

ACKNOWLEDGMENTS

This project, under grant 2009-GRT-026, has been funded with support from Fusion from Energy and funding from the United Kingdom Engineering and Physical Sciences Research Council. This publication reflects the views only of the author, and neither Fusion for Energy nor EPSRC can be held responsible for any use which may be made of the information contained therein.

REFERENCES

1. Durodie et al: this conference.
2. Nightingale et al: *18th Topical Conference on RF Power in Plasmas*, Gent, Belgium AIP Conference Proceedings 1187 (2009) pp213-220